

Shuttle/Payload Interface Definition Document
for the **Payload and General Support
Computer (PGSC)**

Space Shuttle Vehicle Engineering Office

Baseline

July 1999

NASA

National Aeronautics and
Space Administration

Lyndon B. Johnson Space Center
Houston, Texas 77058

**Shuttle/Payload Interface Definition Document
for the
Payload and General Support Computer
July 1999
Baseline**

Approved by

Original Signed By:

B. J. Watkins
Co-Chairman,

Portable Onboard Computer Control Board

Original Signed By:

N. A. Woodbury
Co-Chairman,

Portable Onboard Computer Control Board

NATIONAL AERONAUTICS AND SPACE ADMINISTRATION
LYNDON B. JOHNSON SPACE CENTER
HOUSTON, TEXAS 77058

NOTICE--WHEN ANY GOVERNMENT DRAWINGS, SPECIFICATIONS, OR OTHER DATA ARE USED FOR ANY PURPOSE OTHER THAN IN CONNECTION WITH A DEFINITELY RELATED GOVERNMENT PROCUREMENT OPERATION, THE UNITED STATES GOVERNMENT THEREBY INCURS NO RESPONSIBILITY NOR ANY OBLIGATION WHATSOEVER: AND THE FACT THAT THE GOVERNMENT MAY HAVE FORMULATED, FURNISHED, OR IN ANY WAY SUPPLIED THE SAID DRAWINGS, SPECIFICATION, OR OTHER DATA IS NOT TO BE REGARDED BY IMPLICATION OR OTHERWISE AS IN ANY MANNER LICENSING THE HOLDER OR ANY OTHER PERSON OR CORPORATION, OR CONVEYING ANY RIGHTS OR PERMISSION TO MANUFACTURE, USE, OR SELL ANY PATENTED INVENTION THAT MAY IN ANY WAY BE RELATED THERETO.

INTRODUCTION

The Payload and General Support Computer (PGSC) is a service used to support Shuttle and Payload on-orbit operations. The primary functions are command and display of non-critical payloads and additional crew information services.

The number of PGSC's manifested is determined on a flight-by-flight basis. The Space Shuttle Portable Onboard Computer Control Board determines flight-by-flight configurations. Sufficient PGSC's are always flown to satisfy the requirements of all users and to provide adequate backup capability.

In addition, the PGSC hardware is a Space Shuttle controlled resource. The "flight-like" PGSC system with power supply and communications cabling may be obtained on loan for two weeks. It has the same configuration as the regular flight PGSC and may be used by the user/experimenter for final verification of software/hardware operation and interfacing.

The Portable Onboard Computer Control Board will control changes to this document.

TABLE OF CONTENTS

1.0	SCOPE.....	6
1.1	PURPOSE.....	6
1.2	GENERAL.....	6
1.3	CONFIGURATION CONTROL.....	6
1.4	LOGISTICS.....	6
1.5	CONTACTS.....	6
2.0	APPLICABLE DOCUMENTS.....	8
3.0	OVERVIEW.....	10
3.1	PGSC/THINKPAD 760XD UNMODIFIED INTERFACES.....	18
3.1.1	<i>RS-232 Serial I/O Port.....</i>	<i>18</i>
3.1.2	<i>Parallel Port.....</i>	<i>18</i>
3.1.3	<i>Keyboard/Mouse Connector.....</i>	<i>18</i>
3.1.4	<i>External Display Connector.....</i>	<i>18</i>
3.1.5	<i>Personal Computer Memory Card Internal Association (PCMCIA) slots.....</i>	<i>18</i>
3.1.6	<i>Headphone Jack.....</i>	<i>18</i>
3.1.7	<i>Microphone/Line-in Jack.....</i>	<i>19</i>
3.1.8	<i>External Bus Connector.....</i>	<i>19</i>
3.1.9	<i>Video In.....</i>	<i>19</i>
3.1.10	<i>Video Out.....</i>	<i>19</i>
3.1.11	<i>External Diskette Drive Connector.....</i>	<i>19</i>
3.1.12	<i>Joystick/MIDI.....</i>	<i>19</i>
3.2	EXPANSION UNIT CONFIGURATION.....	19
3.3	EXPANDED/EXTENDED MEMORY.....	20
3.4	ROM BIOS (READ ONLY MEMORY BASIC INPUT/OUTPUT SERVICES).....	20
3.4.1	<i>BIOS Settings.....</i>	<i>20</i>
3.4.2	<i>BIOS Settings Confirmation.....</i>	<i>22</i>
4.0	MECHANICAL.....	25
4.1	PHYSICAL OUTLINE.....	25
4.2	THERMAL.....	25
4.3	VELCRO™ LOCATIONS AND OUTSIDE DIMENSIONS.....	25
4.4	MOUNTING CONSIDERATIONS.....	27
4.5	OPERATING PRESSURE RANGE.....	27
4.6	HUMIDITY.....	27
4.7	WEIGHT.....	27
4.8	ELECTROMAGNETIC COMPATIBILITY (EMC) CONSIDERATIONS.....	27
5.0	POWER REQUIREMENTS.....	29
5.1	ELECTRICAL POWER CHARACTERISTICS.....	29
5.1.1	<i>DC Power.....</i>	<i>29</i>
5.1.2	<i>AC Power.....</i>	<i>29</i>
5.2	CURRENT CHARACTERISTICS FOR POWER ON.....	29
5.2.1	<i>Current for PGSC laptop computer with expansion unit.....</i>	<i>29</i>
5.2.2	<i>Current for PGSC laptop computer only.....</i>	<i>30</i>
5.3	EXTERNAL POWER SUPPLY.....	31
5.4	PAYLOAD-SUPPLIED POWER.....	31
6.0	PGSC-FLIGHT LAPTOP CONFIGURATION OVERVIEW.....	32
6.1	PGSC FLIGHT LAPTOP IRQ TABLE.....	32
6.2	PGSC FLIGHT LAPTOP I/O ADDRESS TABLE.....	33
6.3	PGSC FLIGHT LAPTOP DMA CHANNEL TABLE.....	33

6.4	PGSC FLIGHT LAPTOP MEMORY ADDRESS ALLOCATIONS	33
6.5	CONFIGURATION #1.....	34
6.5.1	<i>Configuration #1 - Standalone with Dual Port RS-422 PC-Card (PCMCIA Card)</i>	34
6.5.2	<i>Configuration #1 - Standalone with RS-422 Usage Table</i>	34
6.6	CONFIGURATION #2.....	35
6.6.1	<i>Configuration #2 - SelectaDock I with PC-Decom (AT-Bus) Card and Dual Port RS-422 PC-Card (PCMCIA Card)</i>	35
6.6.2	<i>Configuration #2 - PC-Decom and RS-422 Usage Table</i>	35
6.7	CONFIGURATION #3.....	35
6.7.1	<i>Configuration #3 - SelectaDock I with OCA (AT-Bus) Card</i>	35
6.7.2	<i>Configuration #3 - OCA Usage Table</i>	36
6.8	CONFIGURATION #4.....	36
6.8.1	<i>Configuration #4 - SelectaDock I with Proshare (AT-Bus) Card and Dual Port RS-422 PC-Card (PCMCIA Card)</i>	36
6.8.2	<i>Configuration #4 - Proshare and RS-422 Usage Table</i>	37
6.9	CONFIGURATION #5.....	37
6.9.1	<i>Configuration #5 - SelectaDock I with Dual Port RS-422 Sealevel AT-Bus Card</i>	37
6.9.2	<i>Configuration #5 - SelectaDock I with Dual Port RS-422 Sealevel Usage Table</i>	38
6.10	RS-232C COMMUNICATIONS	39
6.10.1	<i>RS-232C Line Drivers/Receivers</i>	39
6.11	RS-422A COMMUNICATIONS	39
6.11.1	<i>Quatech PCMCIA RS-422/485 Dual Channel Serial Adapter Card</i>	39
6.11.2	<i>Sealevel ISA RS-422A Serial I/O ISO Communication Card</i>	39
6.11.3	<i>RS-422 Adapter</i>	39
6.12	ETHERNET COMMUNICATIONS	40
6.12.1	<i>3Com Etherlink III LAN PC Card</i>	40
6.13	VIDEO COMMUNICATIONS.....	40
7.0	INTERFACE CABLES.....	41
7.1	POWER CABLES.....	41
7.1.1	<i>PGSC 28V DC Power Cable (25 feet)</i>	41
7.1.2	<i>PGSC 28V DC Power Cable (6 feet)</i>	42
7.1.3	<i>16-20V DC Power Supply Cable (25 feet)</i>	42
7.1.4	<i>AC Power W-Cables</i>	43
7.2	COMMUNICATION CABLES.....	45
7.2.1	<i>RS-232C Cables</i>	45
7.2.2	<i>RS-422A Cables</i>	48
8.0	MISCELLANEOUS.....	52
8.1	APPROVED FLOPPY DISKS.....	52
8.2	APPROVED WRITABLE CDs.....	52
8.3	CD GENERATION PROCEDURES	52
APPENDIX A - ACRONYMS AND ABBREVIATIONS.....		53
ANNEX 1.....		56
	<u><i>PGSC Flight Computer Configuration 1 - Standalone</i></u>	56
	<u><i>PGSC Expansion Assembly Configuration 2 - PCMMU</i></u>	57
	<u><i>PGSC Expansion Assembly Configuration 3 - OCA</i></u>	58
	<u><i>PGSC Expansion Assembly Configuration 4 - ProShare</i></u>	59
	<u><i>PGSC Expansion Assembly Configuration 5 - RS-422</i></u>	60

INDEX OF TABLES

TABLE 3-I. - THINKPAD 760XD/PGSC COMPARISON	17
TABLE 4-I. PGSC COMPONENT WEIGHTS	28
TABLE 5-I. DC POWER TEST RESULTS	29
TABLE 5-2 AC POWER TEST RESULTS*	29
TABLE 7-I. RECOMMENDED CONNECTOR MATES FOR THE RS-232C CABLES.....	45

INDEX OF FIGURES

FIGURE 3-1 PGSC FLIGHT LAPTOP (ISO VIEW)	11
FIGURE 3-2 PGSC FLIGHT LAPTOP (LEFT SIDE)	12
FIGURE 3-3 PGSC FLIGHT LAPTOP (RIGHT SIDE)	12
FIGURE 3-4 PGSC FLIGHT LAPTOP (REAR VIEW)	13
FIGURE 3-5 PGSC FLIGHT LAPTOP WITH EXPANSION UNIT (ISO VIEW)	13
FIGURE 3-6 PGSC FLIGHT LAPTOP WITH EXPANSION UNIT (REAR VIEW) (NO CARD TRAY).....	14
FIGURE 3-7 PGSC AND EXPANSION UNIT WITH CARD TRAY (LEFT SIDE)	14
FIGURE 3-8 PGSC AND EXPANSION UNIT WITH CARD TRAY AND	15
TYPICAL PCMCIA CARD INSTALLED (RIGHT SIDE)	
FIGURE 3-9 PGSC FLIGHT LAPTOP DC POWER INTERFACE DIAGRAM.....	15
FIGURE 3-10 PGSC FLIGHT LAPTOP WITH EXPANSION UNIT AC POWER INTERFACE DIAGRAM	16
FIGURE 4-1 PGSC FLIGHT LAPTOP BOTTOM VELCRO™ PLACEMENT (INFORMATION ONLY)....	26
FIGURE 4-2 PGSC EXPANSION UNIT BOTTOM VELCRO™ PLACEMENT (INFORMATION ONLY)..	26
FIGURE 5-1 POWER ON AC CURRENT REQUIREMENT	30
FIGURE 5-2 POWER ON DC CURRENT REQUIREMENT	30
FIGURE 5.3 EXTERNAL 2.6 AMP DC POWER SUPPLY	30
FIGURE 6-1 WIRING DIAGRAM, RS-422 ADAPTER	40
FIGURE 7-1. 28V DC POWER CABLE (25 FEET)	41
FIGURE 7-2. 28V DC POWER CABLE (6 FEET)	42
FIGURE 7-3 16-20V DC POWER CABLE (25 FEET)	42
FIGURE 7-4 AC POWER W-CABLE - SED46117063	43
FIGURE 7-5 AC POWER W-CABLE - SED46117140-301.....	44
FIGURE 7-6 AC POWER W-CABLE EXTENSIONS- SED4611714-302 THROUGH -305	45
FIGURE 7-7 DB9F TO DB25M RS-232C CABLE SCHEMATIC.....	46
FIGURE 7-8 DB9F TO DB9M RS-232C CABLE SCHEMATIC.....	47
FIGURE 7-9 COMPUTER INTERFACE PANEL	48
FIGURE 7-10 PAYLOAD DATA INTERFACE PANEL	48
FIGURE 7-11 RS-422/CHANNEL 1 CABLE SCHEMATIC	49
FIGURE 7-12 RS422Y/CABLE SCHEMATIC	50
FIGURE 7-13 SED39126962 - PDIP RS-422 Y CABLE	51

1.0 SCOPE

1.1 PURPOSE

The purpose of this document is to:

- a. Define and control the interfaces provided by the PGSC and associated components for use by payloads and crew software, and
- b. Define and control constraints observed by payload and crew support users.

1.2 GENERAL

This document defines all interfaces available to the PGSC assembly and identifies configurations for the government furnished equipment (GFE) communications and power cables supplied with the PGSC assembly.

In this document, the term "PGSC Flight Laptop" refers to the flight ThinkPad 760XD computer as modified: whereas, the term "ThinkPad 760XD" refers to the commercial IBM ThinkPad 760XD sold by the manufacturer.

In the text, the terms "shall," "will," and "must" are used when compliance is mandatory. "May" or "should" indicate a choice exists.

1.3 CONFIGURATION CONTROL

The Space Shuttle Program Portable Onboard Computer Control Board will maintain configuration control of this document in accordance with the Shuttle/Payload Configuration Management Plan for the Payload and General Support Computer (PGSC), JSC 27891.

1.4 LOGISTICS

The payload integration plan (PIP) will clearly define the role of the PGSC for each specific payload. The SSP is responsible for maintaining flight-ready PGSC systems for operation as authorized by the PIP. Section 3 provides an overview of the various PGSC hardware items. Standard Flight PGSC configurations are provided in Annex 1. If you have questions about PGSC logistics, please contact one of the Portable Onboard Computer Control Board Co-Chairmen, B. Watkins at (281) 244-1335 or N. Woodbury at (281) 244-5790.

1.5 CONTACTS

NASA/Johnson Space Center, mail code MV2
 Avionics and Software Office
 Bobby Watkins, (281) 244-1335, Portable Onboard Computer Co-Chairman

NASA/Johnson Space Center, mail code EA5
 Biomedical Hardware Development Office
 David Stephenson, (281) 483-5859

NASA/Johnson Space Center, mail code DL4
Portable Onboard Computing and Tools
Neil Woodbury, (281) 244-5790, Portable Onboard Computer Co-Chairman

NASA/Johnson Space Center, mail code DO5
Payload Operations Branch
Project Engineer for applicable payload

NASA/Johnson Space Center, mail code DL42
Mission Operations Procedures Branch
POC Coordinator for applicable flight

2.0 APPLICABLE DOCUMENTS

The following documents form a part of this document to the extent specified herein. In the event of conflict between the documents referenced and the contents of this document, the contents of this document shall be considered a superseding requirement.

U.S. Government Documents

FED STD 1020A	Telecommunications Electrical Characteristics of Balanced Voltage Digital Interface Circuits
NSTS 1700.7B	Safety Policy and Requirements for Payloads Using the Space Transportation System, January 1989

NASA documents

NSTS 07700, Volume XIV	Space Shuttle System Payload Accommodations (and 10 appendixes)
NSTS 21000-IDD-MDK	Shuttle/Payload Interface Definition Document for Middeck Accommodations
JSC 27891	Shuttle/Payload Configuration Management Plan for the Payload and General Support Computer (PGSC)
JSC 28015	Payload and General Support Computer (PGSC) Discrepancy Reporting Procedures
JSC 28060	Portable Onboard Computer Software Management Plan
JSC 17038	SSP Flight Equipment Non-Critical Hardware Program Requirements Document
JSC 27394	Orbiter Communications Adapter (OCA) End Item Specification Document

Industry documents

ThinkPad	ThinkPad 760XD/760XL/765D/765L User's Guide, July 1997 International Business Machines Corporation Armonk, NY.
EIA STD RS232C	Electronic Industries Association (EIA) Recommended Standards (RS) 232C: Interface between data terminal equipment and data circuit-terminating equipment employing serial binary data interchange.
EIA STD RS422A	Electronic Industries Association (EIA) Recommended Standards (RS) 422A: Electrical characteristics of balanced voltage digital

interface circuits.

Industry documents (continued)

IBM	Select-a-Dock User's Guide, July 1997 International Business Machines Corporation Armonk, NY.
INTEL	ProShare™ Personal Conferencing Video System User's Guide ProShare Video System 150 Intel Corporation, 1995
QUATECH	DSP-200/300 User's manual Dual Channel RS-422/485 PCMCIA Asynchronous Adapter Quatech Incorporated, 1996
SEALEVEL	ACB-530 Part #4111 users manual Sealevel Systems Incorporated, 1994 IS0-COMM part no. 3417 users manual Sealevel Systems Incorporated, 1992
WIGSD	Windows Interface Guidelines for Software Design Microsoft Corporation, 1995
3Com	3Com Etherlink III User's Manual 3C589D-COMBO 3Com Incorporated, 1996

3.0 OVERVIEW

The PGSC computer assembly is a ThinkPad 760XD model laptop computer that is IBM AT-Bus/PCI compatible, and has been modified for use in the Orbiter environment. The PGSC computer assembly and the following hardware items are GFE and are available for use on Space Shuttle missions. This list only represents commonly used GFE items. (Note: Contact B. Watkins at (281) 244-1335 or N. Woodbury at (281) 244-5790 for current GFE hardware items and for current versions of software).

- a) PGSC Flight Laptop (IBM ThinkPad 760XD)
- b) removable floppy drive
- c) external floppy drive case
- d) removable hard drive (3.0 GB)
- e) removable CD-ROM drive (8X)
- f) NiMH battery pack
- g) expansion unit (SelectaDock I)
- h) power supply power cable
- i) 28V DC power supply assembly
- j) PCMMU cable (24 ft.)
- k) RS-422 Y cable (15 ft.)
- l) RS-422 cable (25 ft.)
- m) RS-422 Quatech Card/Cable Assembly
- n) RS-422 Adapter
- o) Video in/out cable assembly
- p) DC power cable (25 ft.)
- q) DC power cable (6 ft.)
- r) AC W power cable
- s) RS-232 quad cable
- t) RS-232C cable (25-9 pin)
- u) RS-232A cable (9-9 pin)
- v) RS-232 Y cable
- w) PDIP RS-422 Y cable
- x) OCA Ku-Band/Audio Cable
- y) PCMCIA Ethernet card with cable
- z) PGSC Flight Laptop expansion assembly (PCMMU board)
- aa) PGSC Flight Laptop expansion assembly (OCA board)
- bb) PGSC Flight Laptop expansion assembly (Proshare board)
- cc) PGSC Flight Laptop expansion assembly (RS-422 ISO Com PC board)

The figures in this section represent various views of the PGSC Flight Laptop and the Expansion Unit assemblies. Figures 3-1 through 3-8 depict the standard connectors found on the ThinkPad 760XD and Expansion Unit assemblies as described in paragraph 3.1 and 3.2, respectively. Figures 3-9 and 3-10 depict the DC and AC power interface diagrams.

Table 3-I is a summary comparison of the ThinkPad 760XD and the PGSC Flight Laptop assembly.

Most information required by PGSC users can be found in the IBM ThinkPad 760XD/760XL/765D/765L User's Guide, dated July 1997 listed in Section 2.0 Applicable Documents.



FIGURE 3-1 PGSC FLIGHT LAPTOP (ISO VIEW)

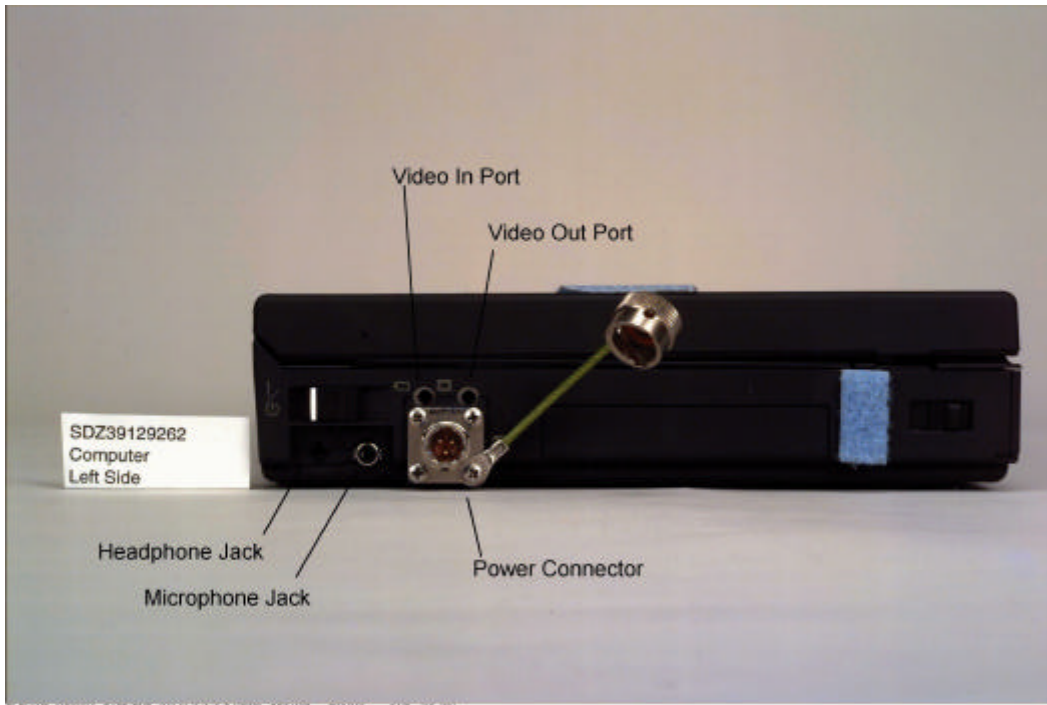

FIGURE 3-2 PGSC FLIGHT LAPTOP (LEFT SIDE)

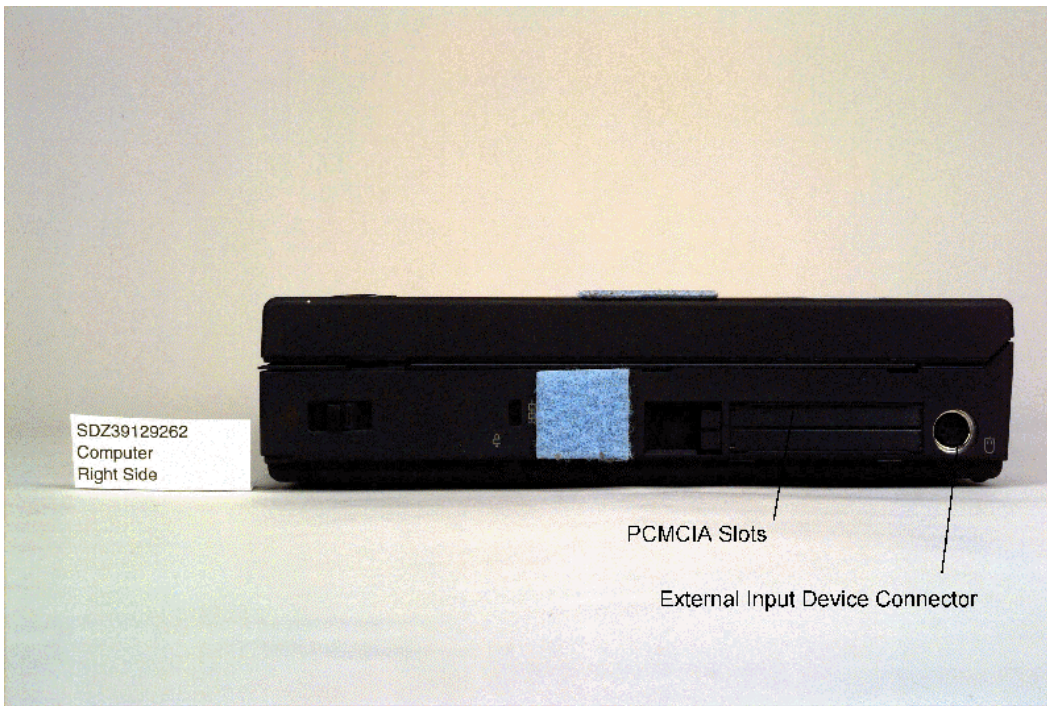

FIGURE 3-3 PGSC FLIGHT LAPTOP (RIGHT SIDE)

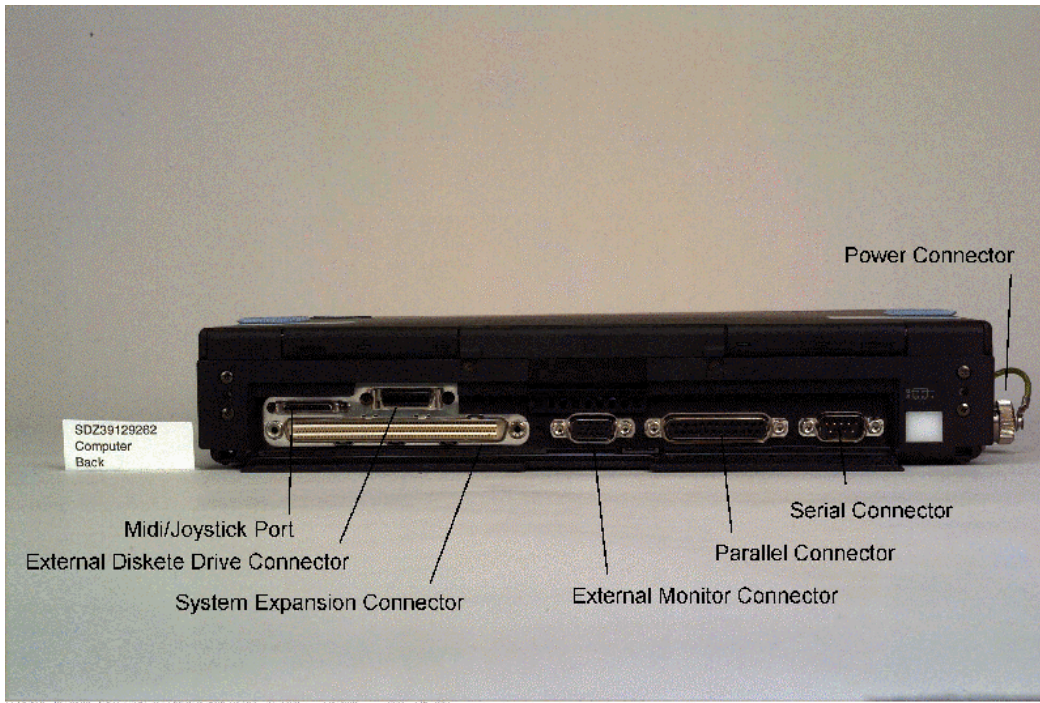

FIGURE 3-4 PGSC FLIGHT LAPTOP (REAR VIEW)



FIGURE 3-5 PGSC FLIGHT LAPTOP WITH EXPANSION UNIT

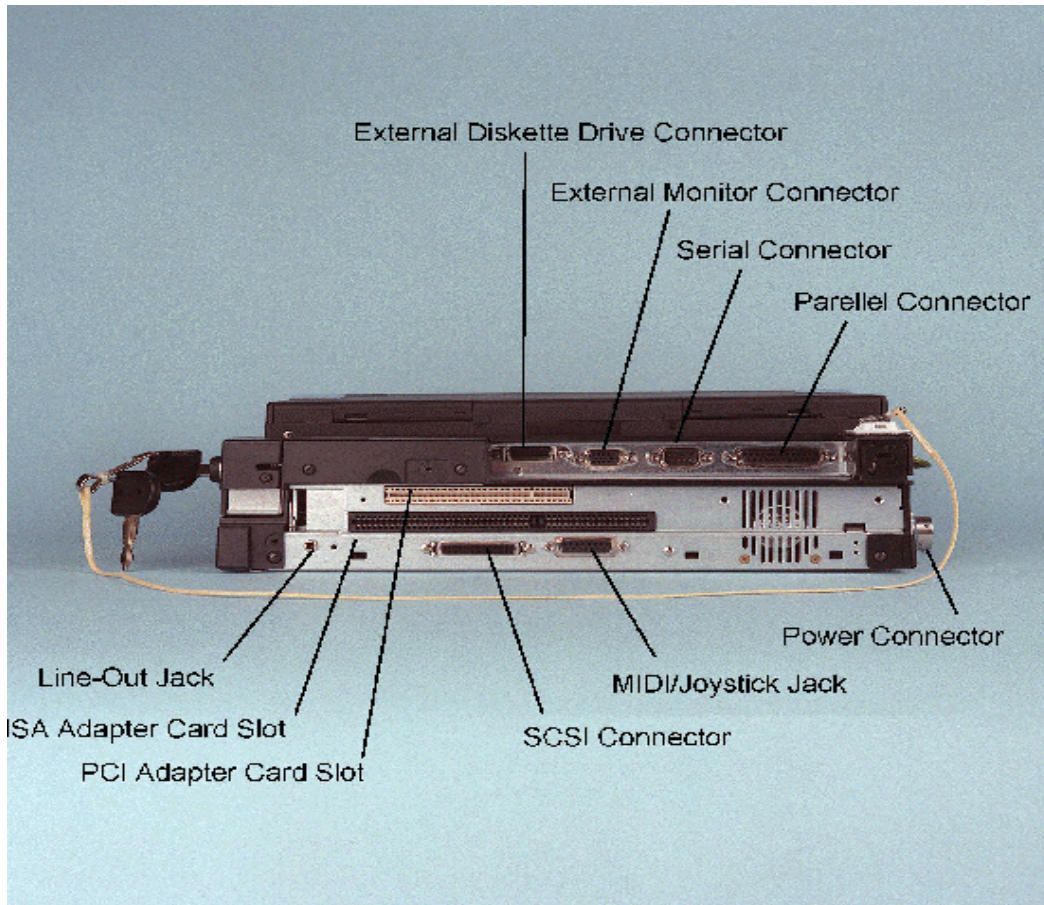

FIGURE 3-6 PGSC FLIGHT LAPTOP WITH EXPANSION UNIT (REAR VIEW) (NO CARD TRAY)

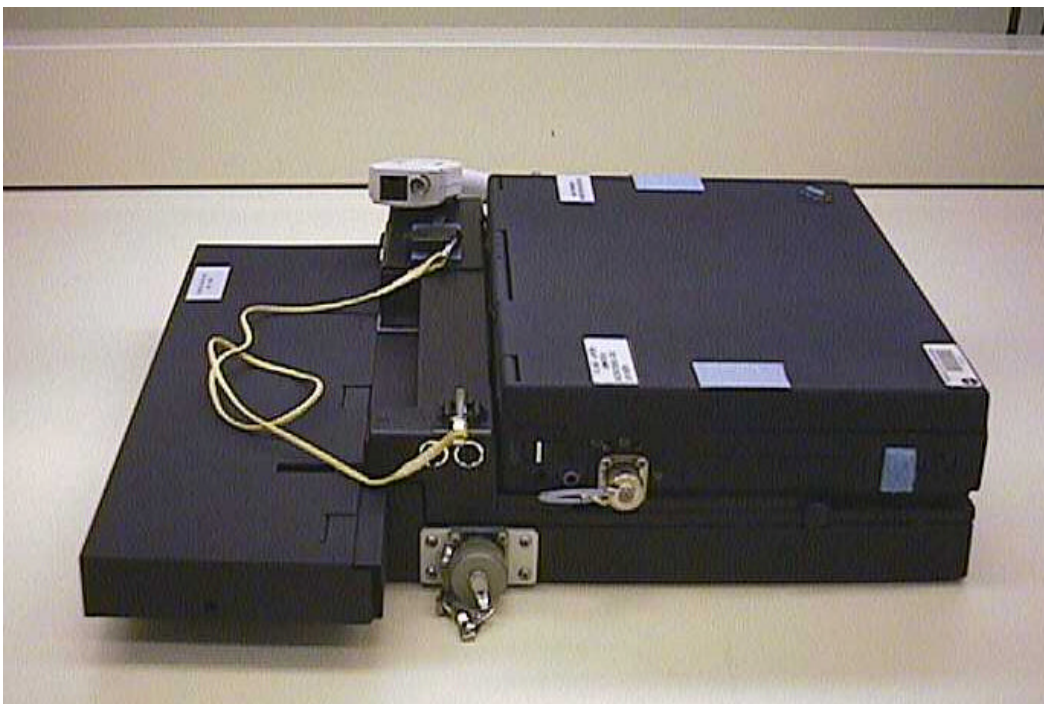

FIGURE 3-7 PGSC AND EXPANSION UNIT WITH CARD TRAY (LEFT SIDE)

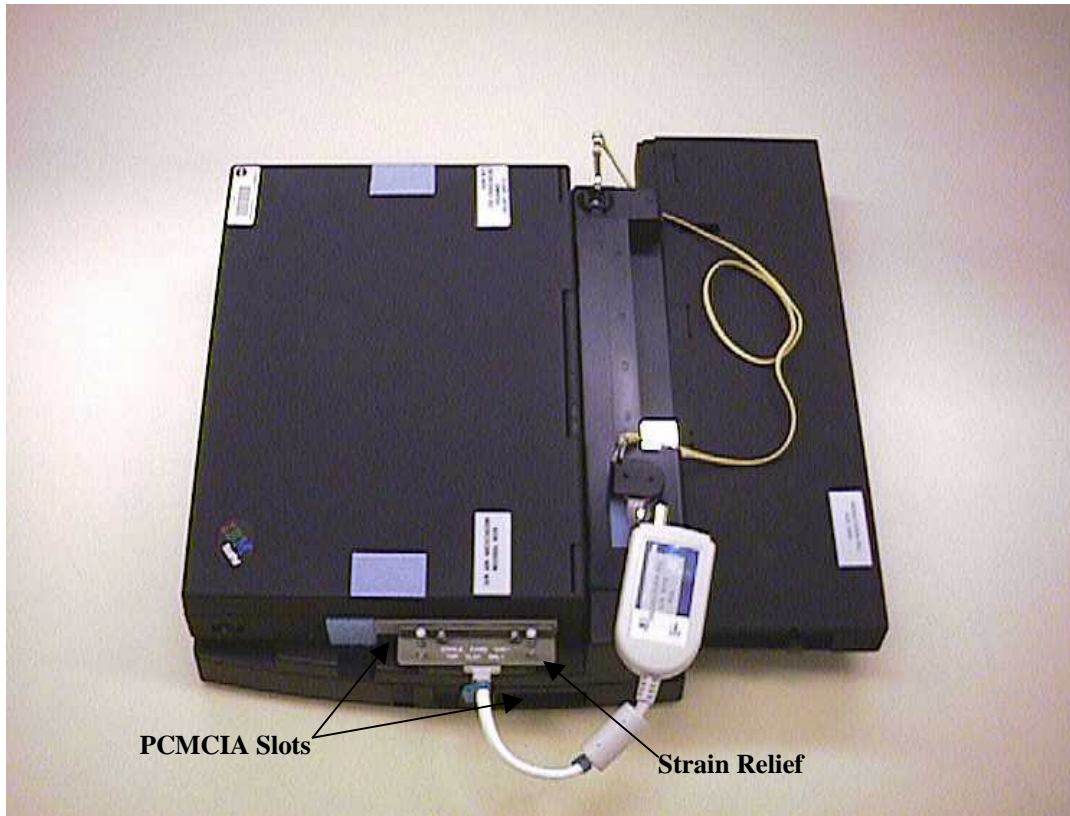

FIGURE 3-8 PGSC AND EXPANSION UNIT WITH CARD TRAY AND TYPICAL PCMCIA CARD INSTALLED (RIGHT SIDE)

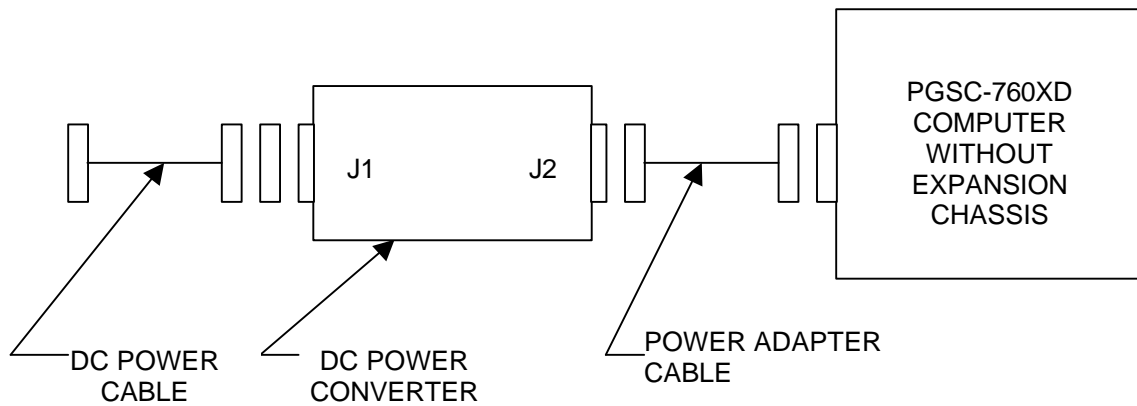

FIGURE 3-9 PGSC FLIGHT LAPTOP DC POWER INTERFACE DIAGRAM

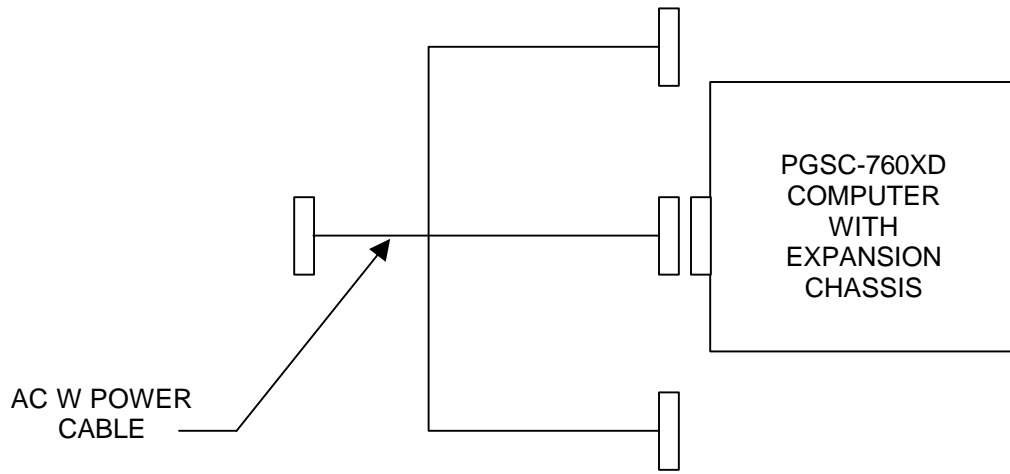

FIGURE 3-10 PGSC FLIGHT LAPTOP WITH EXPANSION UNIT AC POWER INTERFACE DIAGRAM

TABLE 3-I. - ThinkPad 760XD/PGSC Comparison

	ThinkPad 760XD	PGSC Flight Laptop
32-bit 166 MHz Pentium MMX CPU	yes	Yes
Floating Point Unit (FPU)	yes	Yes
System memory (DRAM standard/optional)	32/104 Meg	64 Meg
2 Mb VRAM for display subsystem	yes	Yes
512 kb BIOS Flash ROM	yes	Yes
XGA Color screen	yes	Yes
1024 x 768 x 65536 pixel resolution	yes	Yes
Bit-mapped graphic display capability	yes	Yes
External XGA compatible monitor connector	yes	Yes
84 keys of standard IBM AT	yes	Yes
External keyboard/mouse/keypad connector	yes	Yes
One 3.5 in., 1.44 Mb internal floppy disk drive (removable)	yes	Yes
External floppy drive connector	yes	Yes
One removable hard disk drive	up to 5.7 GB	3.0 GB
One parallel printer port	yes	Yes
One 28.8 baud modem (COM2)	yes	No*
One RS-232C port (COM1)	yes	Yes
Two isolated RS-422A ports (COM2, COM4)	no	PCMCIA card
240-pin PCI/ISA Expansion Bus	yes	Yes
28-Vdc isolated external power supply	no	Yes*
Isolated internal dc power supply	yes	Yes
Internal cooling fan	yes	Yes
Internal dc power supply voltage	20V	20V
PCMCIA Connector	yes	Yes
L1 Cache	32 KB	32 KB
L2 Cache	256 KB	256 KB
CMOS	128 Bytes	128 Bytes
EEPROM	1 KB	1 KB
Audio	Mwave 2780	Mwave 2780
Infrared	500 KHz	Disabled

* Modifications to the ThinkPad 760XD for the PGSC

3.1 PGSC/ThinkPad 760XD UNMODIFIED INTERFACES

The PGSC Flight Laptop assembly is equipped with twelve IBM standard interfaces as supplied by the original manufacturer, IBM Corporation. The ThinkPad 760XD 28.8-baud modem was removed for the flight configuration to accommodate power modifications. The interfaces are:

- RS-232 serial input/output (I/O) port
- Parallel connector (Centronics)
- Keyboard/Mouse connector
- External display connector
- PCMCIA slots (accepts two Type I or Type II PC cards, or one Type III PC card)
- Headphone jack
- Microphone/Line-in jack (supports a dynamic microphone or a self-battery-powered condenser microphone)
- External Bus Connector
- Video In
- Video Out
- External Diskette Drive Connector
- Joystick/MIDI

For more detailed information regarding these connectors, see the IBM ThinkPad 760XD/XL, 760E/ED/EL User's Guide.

3.1.1 RS-232 Serial I/O Port

The IBM ThinkPad 760XD provides an IBM AT compatible RS-232 serial I/O port. For more information about this port, see section 7.

3.1.2 Parallel Port

The parallel port is functionally equivalent to the IBM AT printer adapter. The port supports Centronics-type (parallel) printers general-purpose parallel I/O port. The interface is provided through a 25-pin, D-shell, female connector located on the rear panel.

3.1.3 Keyboard/Mouse Connector

This is the port where you connect an external mouse, external keyboard, or external numeric keypad.

3.1.4 External Display Connector

This is the port where you connect the external display.

3.1.5 Personal Computer Memory Card Internal Association (PCMCIA) slots

Accepts two Type I or two Type II PCMCIA cards, or one Type III PCMCIA Card. The PCMCIA slots provide an interface to the computer for data storage, memory, network interface, etc.

3.1.6 Headphone Jack

A 1/8-inch (3.5-mm) diameter jack where a stereo headphone or external speakers connect.

3.1.7 Microphone/Line-in Jack

A 1/8-inch (3.5-mm) diameter jack where a stereo microphone or external audio device is connected.

3.1.8 External Bus Connector

This is the port used to connect the expansion assembly.

3.1.9 Video In

From the video in port you can capture still images or motion video and overlay motion video.

3.1.10 Video Out

From the video out port you can export motion video.

3.1.11 External Diskette Drive Connector

Attach an external diskette drive here to allow both the CD-ROM drive and the diskette drive to be used simultaneously.

3.1.12 Joystick/MIDI

A joystick can be attached here as well as musical instruments with MIDI ports.

3.2 EXPANSION UNIT CONFIGURATION

Details of the standard PGSC Flight Laptop Configurations are provided in Annex 1.

Configuration 1 (PGSC Flight Laptop without Expansion Unit) is listed in this section only to provide completeness for standard configurations. The PGSC with Expansion Assembly (Configuration 2, 3, 4, & 5) contains the interfaces listed in section 3.1 plus the combinations of the following:

Configuration 1

- Stand alone PGSC Flight Laptop without expansion assembly.

Configuration 2

- PCMMU port - The Pulse Code Modulation Master Unit (PCMMU) is the Orbiter central processing unit that includes all of the Orbiter downlink (OD) telemetry. Select PCMMU data may be de-commutated by the PGSC PC-DECOM software and routed via packetized data to other PGSC's.

Configuration 3

- OCA port - The OCA includes two functionally independent sections: the Ku-band interface and the modem interface. The OCA system, consisting of a single printed circuit board, associated software, and interface cable, provides a means for two-way transfer of computer files between a ground-based computer and a Payload and General Support Computer (PGSC) on-board the Orbiter.

Configuration 4

- Proshare (AT-Bus) Card - The Proshare (AT-Bus) Card provides a means for two-way transfer of video teleconferencing sessions between a ground-based computer and a Payload and General Support Computer (PGSC) on-board the Orbiter.

Configuration 5

- 2, 9-pin Serial RS-422 port- Refer to Sealevel users manual for details.

For more detailed information regarding these connectors, see IBM ThinkPad 760XD/XL, 760E/ED/EL User's Guide, IBM Expansion Unit documentation, Sealevel documentation, Quatech documentation, and OCA documentation.

The current expansion assembly configurations 2, 3, 4, and 5 consist of a one-slot expansion unit that supports standard computer cards. When a standard ISA/PCI card is installed, an optional card cage cover is mounted on the rear of the expansion assembly for protection. The typical power usage of the expansion assembly with card(s) is approximately 35 watts.

3.3 EXPANDED/EXTENDED MEMORY

The standard configuration of the PGSC assembly contains 64MB of random access memory (RAM). The PGSC Flight Laptop uses Microsoft Windows 95 system software. This operating systems software was designed to alleviate base memory restrictions and does not require special memory management software used on previous versions of the PGSC. Previously used MS-DOS programs can still be run on the PGSC Flight Laptop using the DOS 7 software provided by Windows 95.

For more information regarding extended or expanded memory management on the PGSC, see [ThinkPad 760XD/XL, 760 E/ED/EL User's Guide](#).

3.4 ROM BIOS (READ ONLY MEMORY BASIC INPUT/OUTPUT SERVICES)

The current ROM BIOS in the PGSC is version 2.02, dated 3-12-98. Upgrades to the BIOS may occur in the future. If application software is dependent upon a certain BIOS version, the BIOS version number is stored in address F000:FFF5 in the PGSC memory in American Standard Code for Information Interchange (ASCII) format.

3.4.1 BIOS Settings

The BIOS settings for the ThinkPad 760XD are as follows:

Power Management

Hibernation File - Enabled

AC Hibernation Timer = 0 (Disabled)
 AC Standby Timer = 0 (Disabled)
 AC Suspend Power Timer = 0 (Disable)
 AC LCD Off Timer = 0 (Disable)
 AC Hard Disk Off Timer = 0 (Disable)
 AC Processor Speed = Maximum
 AC Power Mode = Custom

DC Hibernation Timer = 0 (Disabled)
 DC Standby Timer = 0 (Disabled)
 DC Suspend Power Timer = 0 (Disable)
 DC LCD Off Timer = 59 Minutes
 DC Hard Disk Off Timer = 20 Minutes

DC Processor Speed = Maximum
 DC Power Mode = Custom

Enter Suspend When Lid is Closed = Disabled
 Timer set for Suspend Function = Enabled
 On Low Battery Suspend the Computer = Enabled
 RediSafe Suspend Mode = Disabled
 Use Switch for On/Off (Not Hibernation) = Enabled
 Hibernation from Suspend Timer = Disabled
 Expansion Unit Suspend = Disabled
 LCD Battery Brightness = Normal

Video

Presentation Mode = Enabled
 Screen = LCD and External
 Horizontal and Vertical Expansion = Enabled
 Use <Fn><F8> Key Combination to Toggle Expansion = Enabled
 Enhanced Video = Shares Interrupt of PCI Bus - See Miscellaneous Section

Audio

Digital Signal Processor (DSP) = Enabled
 DSP IRQ = 5
 DSP Address = 4E30
 DSP DMA = 7
 DSP MIDI Function = Disabled
 DSP Soundblaster Emulation = Disabled
 DSP Internal Modem = Disabled
 Warning Beeps = Enabled
 Wakeup on Ring Indicator = Disabled
 LCD Panel Speaker Indicator = Enabled

Infrared Port

Infrared (IR) Data Transmissions = Disabled
 IR Ports = Front and Back
 IR Mode = ThinkPad Format
 IR COM Address = 03E8
 IR IRQ = 4
 IR Infrared Address = 01A0
 IR DMA 3 = Enabled
 Infrared Power = Off

Internal RS-232D Port

Serial Port Power = On
 Serial Port Use = Enabled
 Serial Port Address = COM1

Parallel Port

Parallel Port = Enabled
 Parallel Port Address = LPT1
 Parallel Port Type = Bidirectional

Disk Drives

Floppy Disk Drive = Enabled as External
 Secondary Hard Disk Drive = Enabled (IRQ 15)

Keyboard

<Fn> Key Locked-Down = Disabled
 Keyboard Type Rate = Normal
 TrackPoint III = Enabled

Miscellaneous

PCI IRQ = 11
 Joystick Port = Enabled
 PC CardBus 1 = Disabled
 PC CardBus 2 = Disabled
 Display Startup Screen = Enabled

3.4.2 BIOS Settings Confirmation

The AutoXD utility is a series of batch and executable files that automatically configure an IBM ThinkPad 760ED and 760XD computer. The program is designed to be autonomous and requires very little user inputs.

When completed with the AUTOXD function, the following checklist can be used to verify that the BIOS settings have been properly configured.

The following checklist assumes use of Windows 95 Utility diskette (UTTPFW95) version 4.10 or later for the ThinkPad 760ED/760XD. All items should already be set to their shown value with AUTOXD except as noted.

The following should be checked within "ThinkPad Configuration".

1 - System Information

A - BIOS Part Number =	SKZ39131208 for 760ED SKZ39131209 for 760XD
B - Machine Type =	9546U3A for 760ED 9546U9E for 760XD

2 - TrackPoint

A - TrackPoint - Enabled
B - Mouse Properties Button - Right-Handed
C - Mouse Properties Pointer Trail = Disabled
D - Mouse Properties General = Standard PS/2 Port Mouse

- 3 - Audio
 - A - Audio - Enabled
 - B - Sound Properties - Check Sound Assignments
 - C - Audio - Playback/Recording = Mwave Wave Audio Driver
 - D - CD Music - CD-ROM drive = D:
 - E - CD Music - Headphones = High
- 4 - Infrared
 - A - Infrared - Disabled
- 5 - Accessibility Options
 - A - Fn key lock - Disabled
 - B - Speaker Indicator - Enabled
- 6 - MIDI/Joystick
 - A - MIDI port - Disabled
 - B - Joystick - Enabled
- 7 - Docking Station (Not Used for PCS/SSC)
- 8 - External Display (Settings depend upon software load)
 - A - Display Properties Settings - 800x600 (760ED)
1024x768 (760XD)
 - B - Display Properties Pallet - 24-bit (760ED)
64K (760XD)
- 9 - Parallel Port
 - A - Parallel Port - Enabled
 - B - Operating Mode - Bidirectional
- 10 - LCD
 - A - Screen Blanking - Disabled
 - B - Screen Expansion - Enabled
 - C - Screen Brightness - Normal
- 11 - Enhanced Video / MPEG (Default values)
 - A - Video-Out : Disabled (Indicates that Video-In is Enabled)
 - C - Color Standard - NTSC
 - D - Underscan - Enabled
 - E - Flicker Free - On
- 12 - Internal Modem
 - A - Internal Modem - Disabled
- 13 - Serial Port
 - A - Serial Port - Enabled
- 14 - PC-Card
 - A - Red Bar Next to Icon
 - B - Enabled CardBus - Disabled
- 15 - Ultrabay

A - Secondary IDE Device - Enabled

16 - Power Management

A - Power Properties Power - Advanced

B - Power Properties Power Mode AC - Customized

C - Power Properties Power Mode AC Timers - All 0's

D - Power Properties Processor AC - Maximum

E - Power Properties Power Mode DC - Customized

F - Power Properties Power Mode DC Timers - Suspend 0, Screen 59, HDD 20

G - Power Properties Processor DC - Maximum

17 - Status Bar

A - Customized

B - LCD+External Display

4.0 MECHANICAL

4.1 PHYSICAL OUTLINE

The PGSC Flight Laptop has almost the same footprints as the commercial IBM ThinkPad 760XD. Its dimensions are 2.0 inches high, 11.7 inches wide, and 8.3 inches in depth with display folded down in the stowed position. For the PGSC with expansion assembly the dimensions are 3.5 inches high, 15.5 inches wide, and 16.5 inches in depth.

4.2 THERMAL

One fan is located in the rear of the Expansion Unit Assembly for cooling. There is also a fan mounted internally on the Video card within the IBM ThinkPad 760XD computer with a small outlet vent on the rear of the computer. The fan within the computer is not visible or accessible to the user. The fans in the expansion chassis and computer allow for cooler operation in the microgravity environment. However, testing performed on the computer indicated a 7 degree Fahrenheit exceedance of the 113-degree F allowable touch temperature limit. A waiver for this requirement was applied for and granted (ref. G05149). Do not block the vent or fan during operation of the units.

4.3 Velcro® LOCATIONS AND OUTSIDE DIMENSIONS

The structural interface with habitable modules (Space Shuttle Orbiter, SpaceHab, etc.) is with Velcro™. Refer to drawing SDZ39129262, Computer Assembly, Payload and General Support Computer (PGSC) and SEZ39131224, Expansion Unit Assembly, for details of Velcro™ placement, connectors, and markings. See Figure 4-1 and Figure 4-2 for illustration of Velcro™ placement.

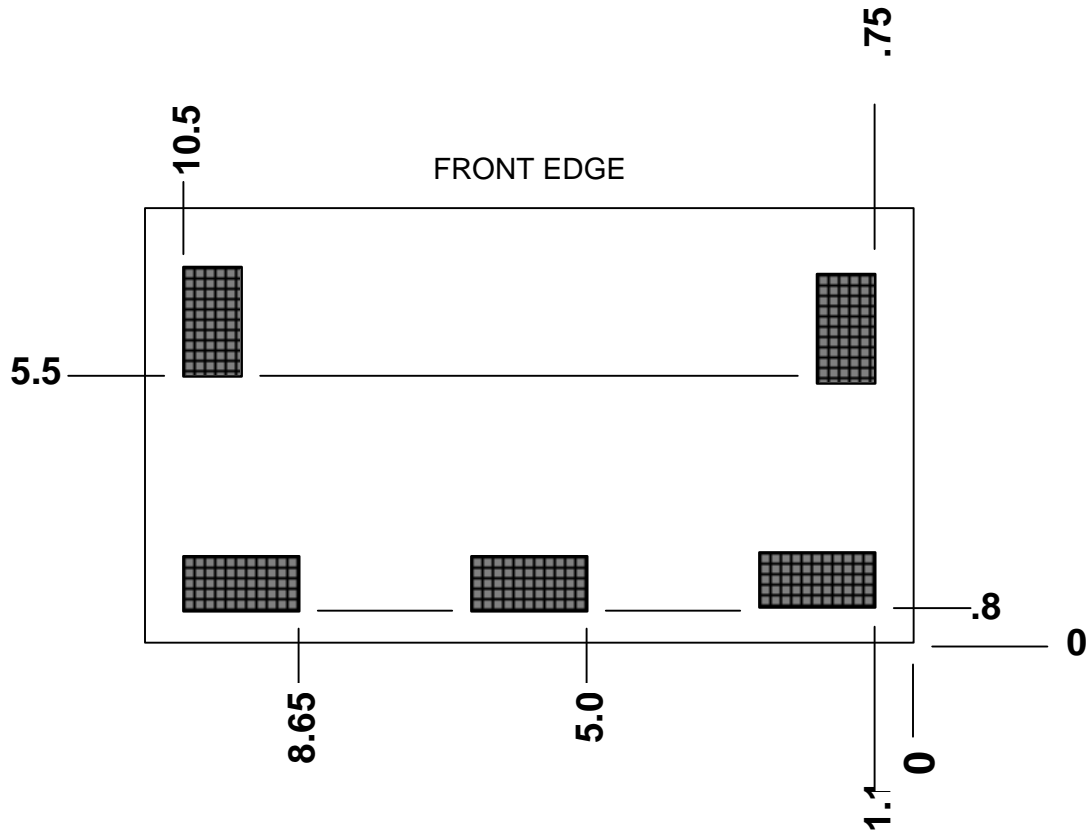

FIGURE 4-1 PGSC FLIGHT LAPTOP BOTTOM VELCRO™ PLACEMENT (INFORMATION ONLY)

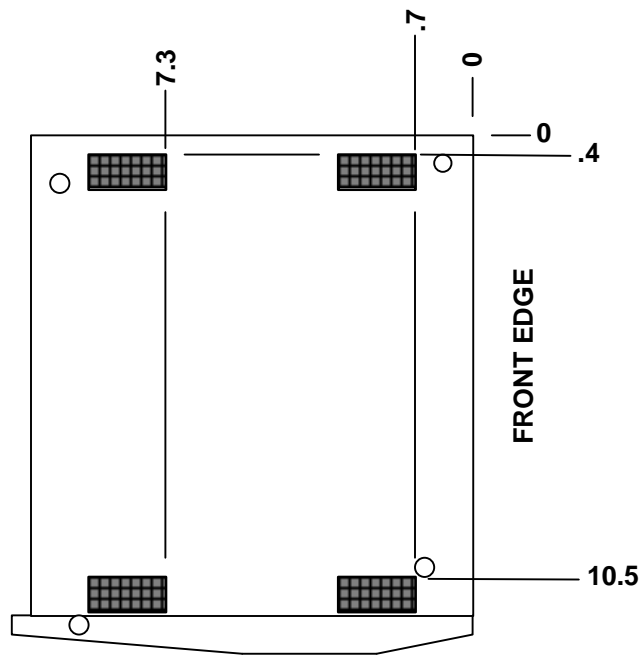

FIGURE 4-2 PGSC EXPANSION UNIT BOTTOM VELCRO™ PLACEMENT (INFORMATION ONLY)

4.4 MOUNTING CONSIDERATIONS

Velcro™ strips are attached to the PGSC to aid in mounting the unit securely in a microgravity environment. When securing the unit, the following should be observed:

- a) Do not block the air vent located on the units
- b) Do not block access to the CD-ROM
- c) Do not block access to side or rear connectors
- d) Do not block access to the PCMCIA slots
- e) Do not block access to the PGSC power switch
- f) Place the unit in an area that allows the screen to be appropriately opened.

4.5 OPERATING PRESSURE RANGE

The PGSC operates at orbiter cabin pressures ranging from 14.7 to 10.2 psi.

4.6 HUMIDITY

The PGSC can operate in normal orbiter cabin humidity.

4.7 WEIGHT

A partial list of PGSC assembly component weights is shown in Table 4-I.

4.8 ELECTROMAGNETIC COMPATIBILITY (EMC) CONSIDERATIONS

The PGSC is certified via the Space Shuttle Program Flight Equipment Non-Critical Hardware Program Requirements Document, JSC-17038, for on Orbit operations. EMC results for standard PGSC configurations can be made available by contacting the Portable Onboard Computer Control Board Co-Chairman, B. Watkins at (281) 244-1335 or N. Woodbury at (281) 244-5790. All non-standard PGSC configurations will have to undergo proper EMC testing.

TABLE 4-I. - PGSC COMPONENT WEIGHTS

	Weight (lb.)
PGSC 760XD Computer	5.01
Removable hard drive 3GB	0.49
Removable 8X CD-ROM	0.8
Removable floppy drive	0.51
External floppy drive case	0.51
Floppy drive bezel	0.01
SelectaDock I Expansion Unit with base and card cover	6.85
Expansion Unit Base	3.15
PCMCIA 260MB Hard Drive	0.2
PCMMU PC board	0.35
RS-422 Iso Com PC board	0.5
RS-422 PC (Quatech) card/cable assembly	0.23
422 Adapter	0.25
AC "W" Cable (15 ft) (SED46117063)	1.4
AC "W" Cable (1.5 ft) (SED46117140)	.63
AC "W" Cable (5 ft extension) (to be used with SED46117140)	.36
AC "W" Cable (10 ft extension) (to be used with SED46117140)	.50
AC "W" Cable (15 ft extension) (to be used with SED46117140)	.64
AC "W" Cable (20 ft extension) (to be used with SED46117140)	.78
DC power cable (25 ft)	1.25
DC power cable (6 ft)	0.5
DC power supply cable	0.75
DC power supply	1.5
PCMMU cable (24 ft)	0.75
PCMMU port mode cable (1 ft)	0.25
RS-422A Y cable (15 ft)	1.5
RS-422 cable (24 ft)	1.75
RS-232A cable (9-pin version)	1.25
RS-232C cable (25-pin version)	1.25
RS-232 Y cable	1.5
Video in/out cable assembly	.09
ProShare PC Board	0.6
Battery Pack NiMH	1.15
RS 422 PDIP Y Cable	2.1
RS 232 Quad Cable	2.4
PCMCIA Ethernet card/Ethernet cable	0.25
OCA Board	0.88
OCA Cable (25 ft)	2.0

5.0 POWER REQUIREMENTS

5.1 ELECTRICAL POWER CHARACTERISTICS

5.1.1 DC Power

Electrical power characteristics were determined by high fidelity testing at the Electrical Power Systems Laboratory using a STS power bus to power a PGSC SED39126010-305 power supply that provided the necessary operating power to the PGSC. Current was measured for different input voltages, and readings were taken at the power source while the PGSC was running a program that caused approximately 75-80% of the screen pixels to be turned on and while the removable Ni-MH battery was charging. Results of the test are shown in Table 5-1.

TABLE 5-1. - DC POWER TEST RESULTS

Input voltage (Vdc)	Current (amps)	Power (watts)
For PGSC only - dc power		
24.0	1.63	39.2
28.0	1.40	39.2
32.0	1.24	39.7

5.1.2 AC Power

AC Electrical power characteristics were determined by connecting an AC power supply to the PGSC Expansion Chassis Assembly. Current was measured for different input voltages, and readings were taken while the PGSC was running a program that caused approximately 75-80% of the screen pixels to be turned on. Results of the test are shown in Table 5-2.

TABLE 5-2 AC POWER TEST RESULTS*

Input voltage (Vac)	Current (mAac)	Power (watts)
For PGSC with Expansion Assembly* using 117 Vac @ 400Hz		
117.0	782.2	58

*Typical Expansion Assembly, Configurations 2, 3, 4, and 5. Results may vary with configuration.

5.2 CURRENT CHARACTERISTICS FOR POWER ON

5.2.1 Current for PGSC laptop computer with expansion unit

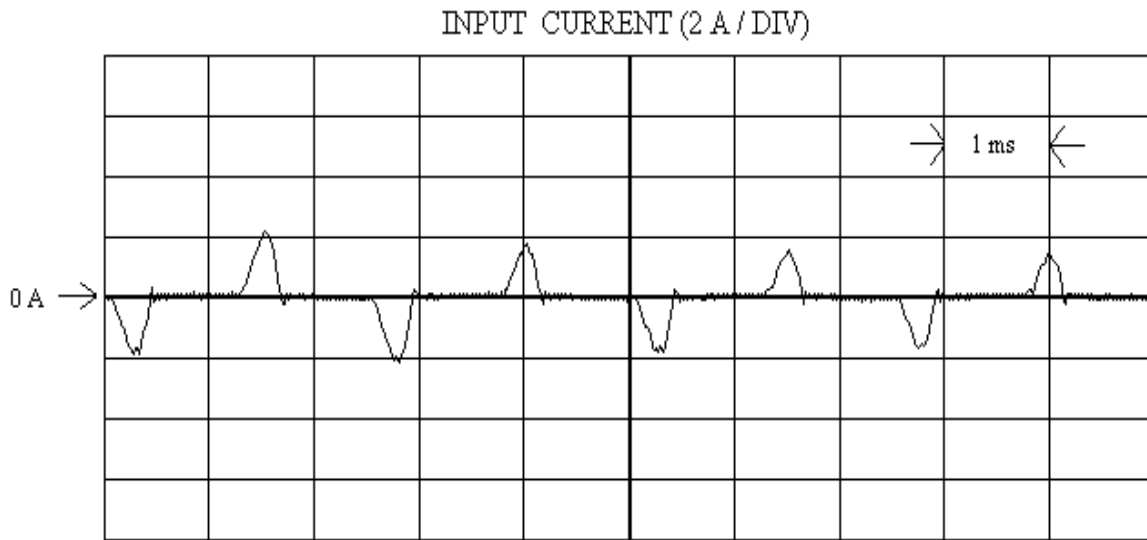

FIGURE 5-1 POWER ON AC CURRENT REQUIREMENT

5.2.2 Current for PGSC laptop computer only

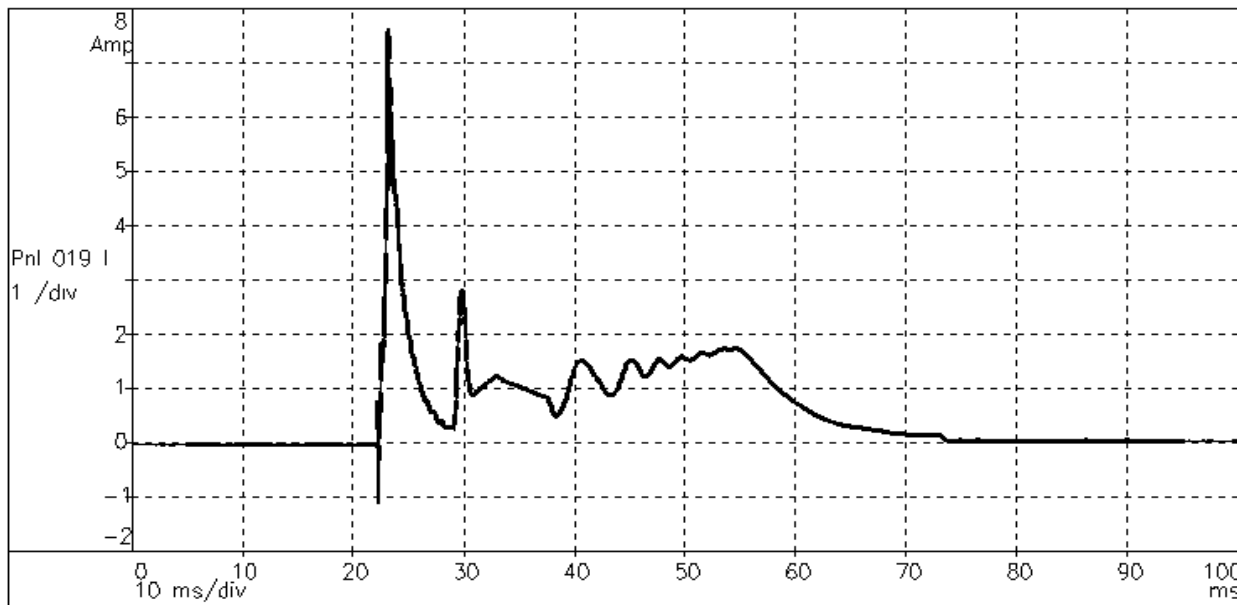

FIGURE 5-2 POWER ON DC CURRENT REQUIREMENT

5.3 EXTERNAL POWER SUPPLY

An external DC to DC power supply is required for the PGSC computer without Expansion Assembly configuration. Figure 5-3 below shows a sketch of an external power supply.

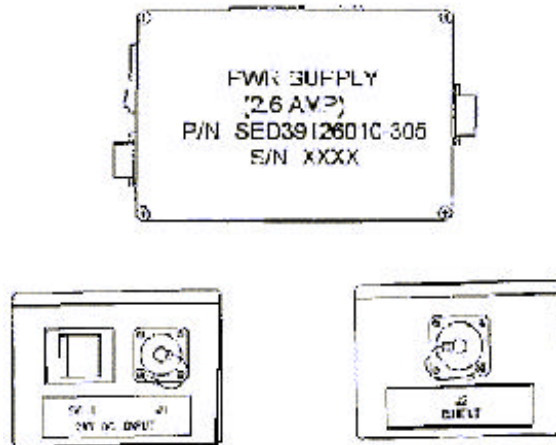

FIGURE 5.3 EXTERNAL 2.6 AMP DC POWER SUPPLY

5.4 PAYLOAD-SUPPLIED POWER

Power may be provided to the PGSC through a middeck payload. The unique payload to the PGSC DC interface cable must be equivalent to the PGSC DC power cable (SED331033334). When using the PGSC with an Expansion Tray, a PGSC AC power cable (SED46117140 or SED46117063), or equivalent, should be used.

6.0 PGSC-Flight Laptop Configuration Overview

Five configurations have been defined for the PGSC Flight Laptop (all configurations can use the 3Com Ethernet PCMCIA card):

- Standalone with RS-422 PCMCIA Card
- Docked with PC-Decom AT-Bus and RS-422 PCMCIA Cards
- Docked with OCA AT-Bus Card (Ku and PADM)
- Docked with Proshare AT-Bus and RS-422 PCMCIA Cards
- Docked with RS-422 Sealevel AT-Bus Card

All Serial Devices use either IRQ4 or IRQ3. Standard I/O Address Are Used for COM1 through COM4. Note: Sealevel Dual Port RS-422 card also uses IRQ10 for second port (set to COM4).

The Mwave Audio Device Uses IRQ5 in all configurations.

The PCMCIA Network Adapter Uses IRQ9 for all configurations.

All AT-Bus Cards Use IRQ10. The SelectaDock I can only house a single AT-Bus card in each configuration. Note: Sealevel Dual Port RS-422 card also uses IRQ3 for the first port.

All PCI-Related items, including SCSI, use IRQ11.

Primary IDE uses IRQ14 and Secondary IDE uses IRQ15 in all configurations.

IRQ3 and IRQ9 can be used by removing either the RS-422 PCMCIA card or the Ethernet PCMCIA card, respectively.

The RS-422 PCMCIA card and OCA/PADM cannot be installed on the same PGSC system due to interrupt and I/O address conflicts.

6.1 PGSC Flight Laptop IRQ Table

The following table lists the interrupt allocations for all configurations. The IRQs are arranged numerically:

IRQ 0 -	System timer
IRQ 1 -	Keyboard
IRQ 2 -	Cascade to IRQ9
IRQ 3 -	OCA (PADM) or Quatech Dual Port RS-422 (COM2 and COM4) or Sealevel RS-422 Port #1 (COM2)
IRQ 4 -	Built-In RS-232 (COM1)
IRQ 5 -	MWave Audio
IRQ 6 -	Floppy Diskette Controller
IRQ 7 -	Parallel Port
IRQ 8 -	Real Time Clock
IRQ 9 -	3Com Ethernet
IRQ 10-	PC-Decom, OCA (Ku), or Proshare or Sealevel RS-422 Port #2 (COM4)
IRQ 11-	PCI (Including SelectaDock I SCSI)
IRQ 12-	Trackpoint III
IRQ 13-	Math Coprocessor
IRQ 14-	HDD / CD-ROM (Primary IDE)
IRQ 15-	Secondary IDE

6.2 PGSC Flight Laptop I/O Address Table

The following table lists the I/O Address allocations for all configurations. The addresses are arranged numerically (devices which use non-contiguous address will appear multiple times):

Timer	0040-0043
Keyboard	0060, 0064
Mouse	0060, 0064
RTC	0070-0071
Secondary IDE	0170-0177
HDD/CD	01F0-01F7
OCA/PADM	0200-0221
Proshare	0224-0227
PC-Decom	0238-023F
Proshare	0240-024F
OCA/Ku	02E0-02E7
COM4(422)	02E8-02EF
COM2(422)	02F8-02FF
3Com Ethernet	0300-030F
Secondary IDE	0376-0377
Video	03B4-03B5, 03BA
LPT1(Prt)	03BC-03BE
Video	03C0-03CF, 03D4-03D5, 03D8-03DA
PCMCIA	03E0-03E1
PCMCIA Dock	03E2-03E3
COM3	03E8-03EF
FDD	03F0-03F7
CD	03F6-03F7
COM1(232)	03F8-03FF
Video	2100-21FF
Video	43C6-43C9
Video	46E8
Mwave	4E30-4E3F
Video	83C6-83C9
SD-I SCSI II	Set By System Only

6.3 PGSC Flight Laptop DMA Channel Table

The following table lists the DMA Channel allocations for all configurations. The addresses are arranged numerically:

DMA Channels:

0	Unused
1	PC-Decom
2	FDD
3	PC-Decom
4	Unused
5	Unused
6	Unused
7	Mwave

6.4 PGSC Flight Laptop Memory Address Allocations

The following table lists the memory addresses that should be excluded for DOS applications when using an upper memory manager (such as EMM386). In addition to the address shows, memory used by a PCMCIA adapter card should also be excluded. This restriction does not apply to Windows 95 users.

Memory Addresses:

A0000-BFFFF Video
C0000-C7FFF Video

6.5 Configuration #1

6.5.1 Configuration #1 - Standalone with Dual Port RS-422 PC-Card (PCMCIA Card)

Com Port Description	COM Number	IRQ Number	I/O Address Locations	DMA Channel	Controller
Internal RS-232D	COM1	IRQ4	03F8-03FF	N/A	16550 UART Equivalent
PC-Card #1 RS-422 #1	COM2	IRQ3	02F8-02FF	N/A	16550 UART Equivalent
PC-Card #1 RS-422 #2	COM4	IRQ3	02E8-02EF	N/A	16550 UART Equivalent
PC-Card #2 3Com Ethernet Available	N/A	IRQ9	0300-030F	N/A	PC-Card
	N/A	IRQ10	N/A	N/A	N/A

6.5.2 Configuration #1 - Standalone with RS-422 Usage Table

Interrupt Number	Device	I/O Address	DMA Channel
IRQ0	Timer	0040-0043	N/A
IRQ1	Keyboard	0060, 0064	N/A
IRQ2	Cascade Int	N/A	N/A
IRQ3	RS-422 Ports 1 and 2	02F8-02FF 02E8-02EF	N/A
IRQ4	RS-232 on ThinkPad	03F8-03FF	N/A
IRQ5	Mwave Audio	4E30-4E3F	7
IRQ6	Floppy Drive Controller	03F0-03F7	2
IRQ7	Parallel Port	0140-015F	N/A
IRQ8	Real Time Clock	0070-0071	N/A
IRQ9	Ethernet PC-Card	0300-030F	N/A
IRQ10	Unused	N/A	N/A
IRQ11	PCI Bus	N/A	N/A
IRQ12	TrackPoint III Pointing Device	0060, 0064	N/A
IRQ13	Math Coprocessor	N/A	N/A
IRQ14	Primary IDE	01F0-01F7	N/A
IRQ15	Secondary IDE	0170-0177	N/A

6.6 Configuration #2

6.6.1 Configuration #2 - SelectaDock I with PC-Decom (AT-Bus) Card and Dual Port RS-422 PC-Card (PCMCIA Card)

Com Port Description	COM Number	IRQ Number	I/O Address Locations	DMA Channel	Controller
Internal RS-232D	COM1	IRQ4	03F8-03FF	N/A	16550 UART Equivalent
PC-Card #1 RS-422 #1	COM2	IRQ3	02F8-02FF	N/A	16550 UART Equivalent
PC-Card #1 RS-422 #2	COM4	IRQ3	02E8-02EF	N/A	16550 UART Equivalent
PC-Decom AT-Bus	SCC1A and SCC1B	IRQ10	0238-023F	1 and 3	Zilog 8530
SCSI-II Adapter	N/A	IRQ11 (PCI)	Set By System	N/A	Internal to SelectaDock I
PC-Card #2 3Com Ethernet	N/A	IRQ9	0300-030F	N/A	PC-Card

6.6.2 Configuration #2 - PC-Decom and RS-422 Usage Table

Interrupt Number	Device	I/O Address	DMA Channel
IRQ0	Timer	0040-0043	N/A
IRQ1	Keyboard	0060, 0064	N/A
IRQ2	Cascade Int	N/A	N/A
IRQ3	RS-422 Ports 1 and 2	02F8-02FF 02E8-02EF	N/A
IRQ4	RS-232 on ThinkPad	03F8-03FF	N/A
IRQ5	Mwave Audio	4E30-4E3F	7
IRQ6	Floppy Drive Controller	03F0-03F7	2
IRQ7	Parallel Port	0140-015F	N/A
IRQ8	Real Time Clock	0070-0071	N/A
IRQ9	Ethernet PC-Card	0300-030F	N/A
IRQ10	PC-Decom	0238-023F	1 and 3
IRQ11	PCI Bus / SCSI-II	Set by System	N/A
IRQ12	TrackPoint III Pointing Device	0060, 0064	N/A
IRQ13	Math Coprocessor	N/A	N/A
IRQ14	Primary IDE	01F0-01F7	N/A
IRQ15	Secondary IDE	0170-0177	N/A

6.7 Configuration #3

6.7.1 Configuration #3 - SelectaDock I with OCA (AT-Bus) Card

Com Port Description	COM Number	IRQ Number	I/O Address Locations	DMA Channel	Controller
Internal RS-232D	COM1	IRQ4	03F8-03FF	N/A	16550 UART Equivalent
OCA/PADM AT-Bus	COM2	IRQ3	02F8-02FF	N/A	Unique
OCA/Ku-Band AT-Bus	N/A	IRQ10	02E0-02E7	N/A	Unique
SCSI-II Adapter	N/A	IRQ11 (PCI)	Selected by System	N/A	Internal to SelectaDock I
PC-Card #1	N/A	IRQ9	0300-030F	N/A	PC-Card
3Com Ethernet					

6.7.2 Configuration #3 - OCA Usage Table

Interrupt Number	Device	I/O Address	DMA Channel
IRQ0	Timer	0040-0043	N/A
IRQ1	Keyboard	0060, 0064	N/A
IRQ2	Cascade Int	N/A	N/A
IRQ3	OCA/PADM	0200-0221	N/A
		02F8-02FF	
IRQ4	RS-232 on ThinkPad	03F8-03FF	N/A
IRQ5	Mwave Audio	4E30-4E3F	7
IRQ6	Floppy Drive Controller	03F0-03F7	2
IRQ7	Parallel Port	0140-015F	N/A
IRQ8	Real Time Clock	0070-0071	N/A
IRQ9	Ethernet PC-Card	0300-030F	N/A
IRQ10	OCA/Ku Band	02E0-02E7	N/A
IRQ11	PCI Bus / SCSI-II	Set By System	N/A
IRQ12	TrackPoint III Pointing Device	0060, 0064	N/A
IRQ13	Math Coprocessor	N/A	N/A
IRQ14	Primary IDE	01F0-01F7	N/A
IRQ15	Secondary IDE	0170-0177	N/A

6.8 Configuration #4

6.8.1 Configuration #4 - SelectaDock I with Proshare (AT-Bus) Card and Dual Port RS-422 PC-Card (PCMCIA Card)

Com Port Description	COM Number	IRQ Number	I/O Address Locations	DMA Channel	Controller
----------------------	------------	------------	-----------------------	-------------	------------

Internal RS-232D	COM1	IRQ4	03F8-03FF	N/A	16550 UART Equivalent
PC-Card #1 RS-422 #1	COM2	IRQ3	02F8-02FF	N/A	16550 UART Equivalent
PC-Card #1 RS-422 #2	COM4	IRQ3	02E8-02EF	N/A	16550 UART Equivalent
Proshare AT-Bus	N/A	IRQ10	0224-0227	N/A	Unique
SCSI-II Adapter	N/A	IRQ11 (PCI)	Selected by System	N/A	Internal to SelectaDock I
PC-Card #2 3Com Ethernet	N/A	IRQ9	0300-030F	N/A	PC-Card

6.8.2 Configuration #4 - Proshare and RS-422 Usage Table

Interrupt Number	Device	I/O Address	DMA Channel
IRQ0	Timer	0040-0043	N/A
IRQ1	Keyboard	0060, 0064	N/A
IRQ2	Cascade Int	N/A	N/A
IRQ3	RS-422 Ports 1 and 2	02F8-02FF 02E8-02EF	N/A
IRQ4	RS-232 on ThinkPad	03F8-03FF	N/A
IRQ5	Mwave Audio	4E30-4E3F	7
IRQ6	Floppy Drive Controller	03F0-03F7	2
IRQ7	Parallel Port	0140-015F	N/A
IRQ8	Real Time Clock	0070-0071	N/A
IRQ9	Ethernet PC-Card	0300-030F	N/A
IRQ10	Proshare	0224-0227 0240-024F	N/A
IRQ11	PCI Bus / SCSI-II	Set By System	N/A
IRQ12	TrackPoint III Pointing Device	0060, 0064	N/A
IRQ13	Math Coprocessor	N/A	N/A
IRQ14	Primary IDE	01F0-01F7	N/A
IRQ15	Secondary IDE	0170-0177	N/A

6.9 Configuration #5

6.9.1 Configuration #5 - SelectaDock I with Dual Port RS-422 Sealevel AT-Bus Card

Com Port Description	COM Number	IRQ Number	I/O Address Locations	DMA Channel	Controller
Internal RS-232D	COM1	IRQ4	03F8-03FF	N/A	16550 UART Equivalent

Sealevel AT-Bus RS-422 #1	COM2	IRQ3	02F8-02FF	N/A	16550 UART Equivalent
Sealevel AT-Bus RS-422 #2	COM4	IRQ10	02E8-02EF	N/A	16550 UART Equivalent
PC-Card #2 3Com	N/A	IRQ9	0300-030F	N/A	PC-Card
Ethernet SCSI II Adapter	N/A	IRQ11 (PCI)	N/A	N/A	Internal to SelectaDock I

6.9.2 Configuration #5 - SelectaDock I with Dual Port RS-422 Sealevel Usage Table

Interrupt Number	Device	I/O Address	DMA Channel
IRQ0	Timer	0040-0043	N/A
IRQ1	Keyboard	0060, 0064	N/A
IRQ2	Cascade Int	N/A	N/A
IRQ3	RS-422 Port #1 (COM2)	02F8-02FF	N/A
IRQ4	RS-232 on ThinkPad	03F8-03FF	N/A
IRQ5	Mwave Audio	4E30-4E3F	7
IRQ6	Floppy Drive Controller	03F0-03F7	2
IRQ7	Parallel Port	0140-015F	N/A
IRQ8	Real Time Clock	0070-0071	N/A
IRQ9	Ethernet PC-Card	0300-030F	N/A
IRQ10	RS-422 Port #2 (COM4)	02E8-02EF	N/A
IRQ11	PCI Bus / SCSI-II	Set by System	N/A
IRQ12	TrackPoint III Pointing Device	0060, 0064	N/A
IRQ13	Math Coprocessor	N/A	N/A
IRQ14	Primary IDE	01F0-01F7	N/A
IRQ15	Secondary IDE	0170-0177	N/A

6.10 RS-232C COMMUNICATIONS

The PGSC contains one RS-232C asynchronous serial I/O port that provides a communication link between the PGSC and an external device. This is a standard serial port as defined in EIA STD RS232C. This port is a 9-pin version compatible with an IBM PC-AT 9-pin serial port. For RS-232C cable pin outs and description, see paragraph 7.2.1.

6.10.1 RS-232C Line Drivers/Receivers

The PGSC uses standard bipolar line drivers/receivers, the 1489 transmitter and the 1488 receiver. The 1488 line driver is capable of producing 14.8 mA current. Information regarding the line drivers/receivers is readily available in published data manuals.

6.11 RS-422A COMMUNICATIONS

6.11.1 Quatech PCMCIA RS-422/485 Dual Channel Serial Adapter Card

The Quatech PCMCIA RS-422/485 interface is a standard Commercial off the Shelf (COTS) PC Card 2.1 compliant Type II PCMCIA component which adds two fully independent asynchronous RS-422 interfaces to the PGSC Flight Computer. The card uses a 16550 UART with programmable baud rate and data formats. A maximum serial link of up to 4000 feet may be realized. The RS-422 maximum baud rate is 115.2K. Consult the Quatech DSP-200/300 User's Manual for additional information.

6.11.2 Sealevel ISA RS-422A Serial I/O ISO Communication Card

The Sealevel RS-422A Serial ISO Communication Card is a COTS "SEALEVEL" AT compatible PC board (part number 3417). The ISO-com board uses a 16550 UART with programmable baud rate and data formats. The board allows very long distance (5,000 ft. at 9,600 baud) communication with virtually error free differential drive characteristics. The ISO-com board provides the PGSC with two ground isolated serial ports. NOTE: Certain Expansion Unit configurations have one of the ports disabled. Consult the User's Manual for additional information.

6.11.3 RS-422 Adapter

The RS-422 Adapter is an in-house designed adapter allowing compatible communications between a Quatech PCMCIA RS-422/485 Dual Channel Serial Adapter Card (SDG39129284-301) and other compatible RS-422 communication devices. The adapter applies a termination resistance of 100 Ohms across the Data input and Auxiliary input pins to help eliminate noise from the channel line and allows interface with existing RS-422 flight cables. See figure 6-1 for details

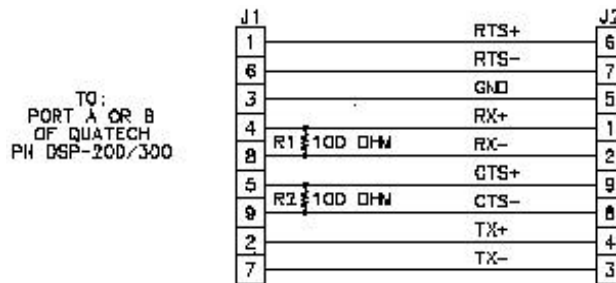

FIGURE 6-1 WIRING DIAGRAM, RS-422 ADAPTER

6.12 Ethernet Communications

6.12.1 3Com Etherlink III LAN PC Card

The 3Com Etherlink III LAN PC Card is a COTS standard Type II PCMCIA Ethernet communications card that is PC Card 2.1 compliant. The 3Com 3C589D-COMBO card is 10BASE-2 and 10BASE-T compatible. A combo cable is attached to the card which allows the use of either a coaxial cable connection via a BNC Connector or a Level 3 twisted pair connection via a RJ-45 Connector. Network segments up to 1000 ft can be attained with a coaxial cable (RG58 C/U) and segments up to 328 ft can be attained with Level 3 unshielded twisted pair. The maximum throughput is 10 Mbps. Consult the 3Com 3C589D-COMBO User's Manual for additional information.

6.13 Video Communications

The PGSC contains one video-in jack and one video-out jack. Either jack requires the use of an IBM COTS modified video interface cable assembly P/N SEZ39131213-301. The color standard is National Television Standards Committee (NTSC) or Phase-Alternation-by-Line (PAL) format. The standard is controlled through software settings. The video cable assembly provides two type of connection: S-Video Jack and Composite Video Jack. The information below describes the video specifications for each of the input/output jacks.

S-Video Jack

- 4-pin mini DIN jack
- Y signal: 1Vpp 75 ohm with negative composite sync
- C signal: 0.286Vpp 75 ohm

Composite Video Jack

- Pin jack
- 1Vpp 75 ohm with negative composite sync

7.0 INTERFACE CABLES

7.1 POWER CABLES

The PGSC Flight Laptop configurations use Space Shuttle 28-Vdc power supplied only through a PGSC DC power cable. If the PGSC is powered through the payload, then the proper connector mates are the following:

dc Cable connector = MS3475L-8-33S

dc Mating connector = MS3470L-8-33P

7.1.1 PGSC 28V DC Power Cable (25 feet)

The dc power cable, part number SED33103334, connects the 28V DC Power Supply with the 28-Vdc Space Shuttle power or experiment dc power. For details see Figure 7-1.

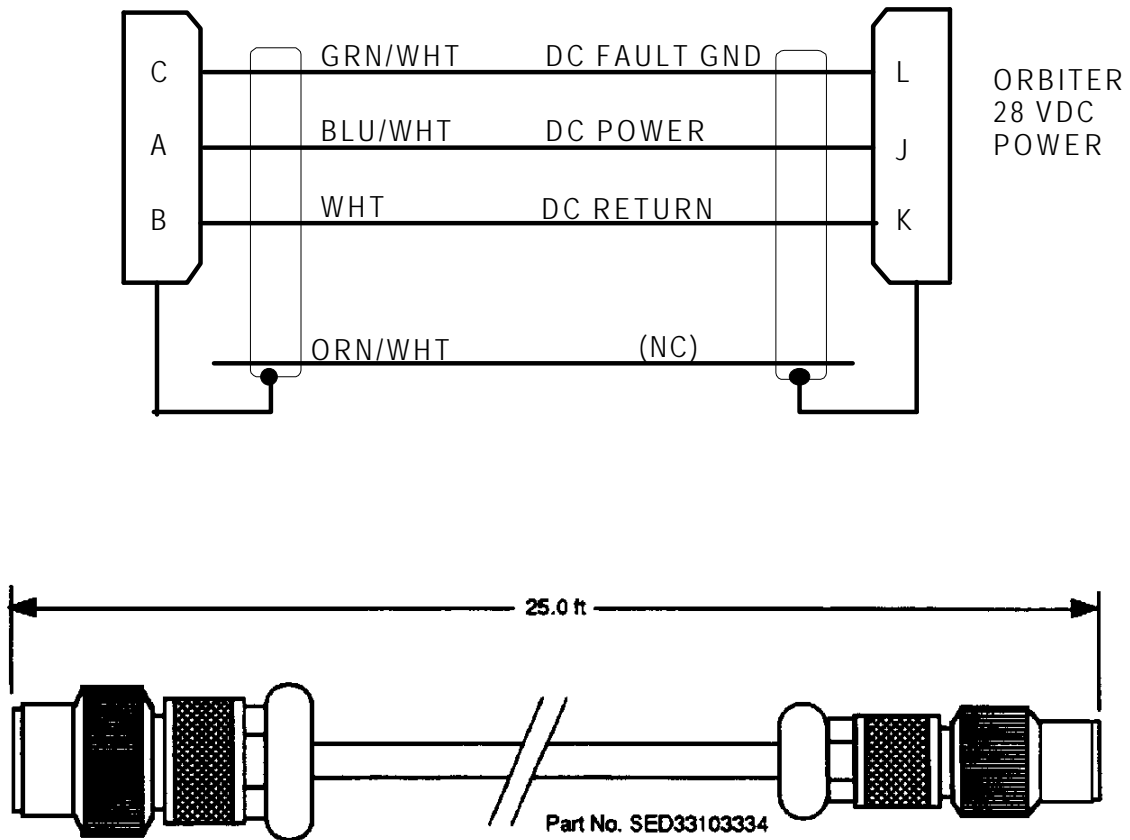

FIGURE 7-1. - 28V DC POWER CABLE (25 FEET)

7.1.2 PGSC 28V DC Power Cable (6 feet)

The dc power cable, part number SED39122875, connects the 28V DC Power Supply with the 28-Vdc Space Shuttle power or experiment dc power. For details, see Figure 7-2.

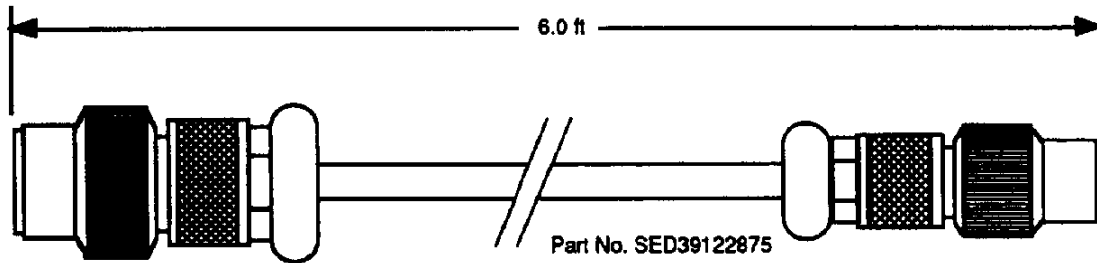

FIGURE 7-2. - 28V DC POWER CABLE (6 FEET)

7.1.3 16-20V DC Power Supply Cable (25 feet)

The dc power supply cable SED39126013 is required with the 28V DC power cable and 28V DC power supply to supply 16-20V DC Power to the PGSC computer configuration only. For details see Figure 7-3.

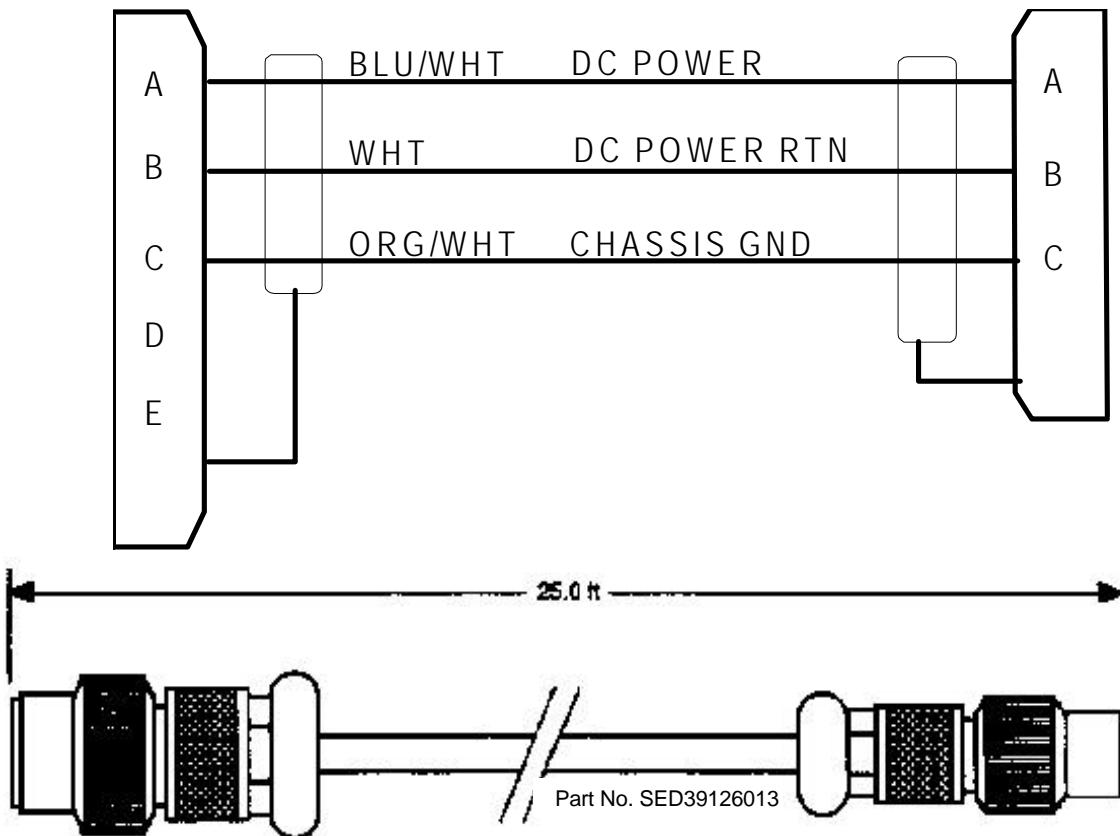

FIGURE 7-3 16-20V DC POWER ADAPTER CABLE (25 FEET)

7.1.4 AC Power W-Cables

AC W cable part numbers SED46117063-301 and SEG46117140-301 connect the PGSC Expansion Unit with the 115V AC 400Hz Space Shuttle power. Use of the SEG46117140-302 through -305 cables allows for customized cable lengths when used with the SEG46117140-301 W cable. Either cable permits the connection of multiple expansion units (up to a maximum of 3) from a single AC power source. For details, see Figure 7-4, Figure 7-5, and Figure 7-6.

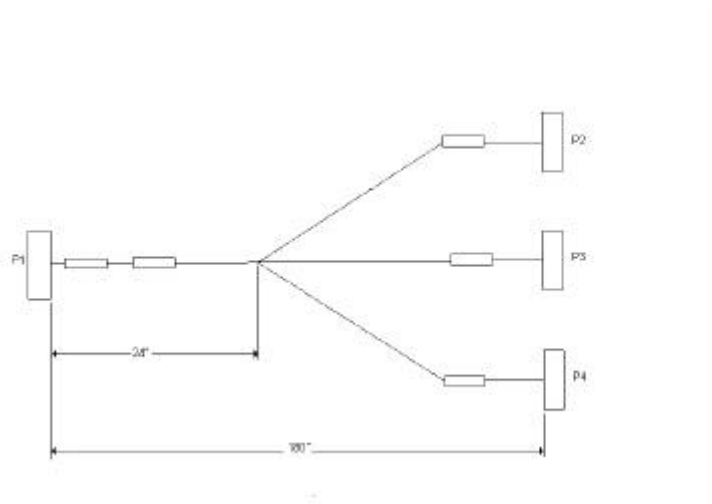
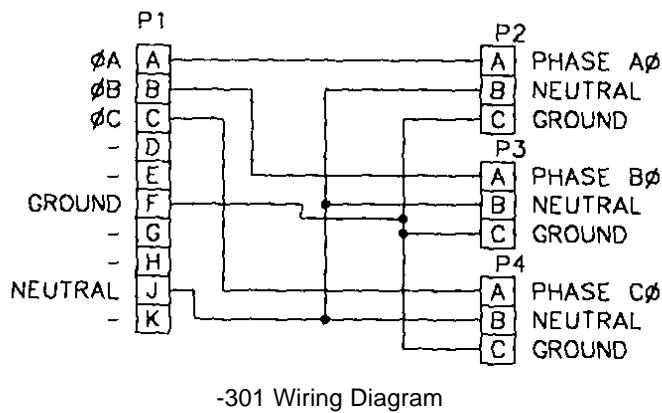

FIGURE 7-4 AC POWER W-CABLE - SED46117063

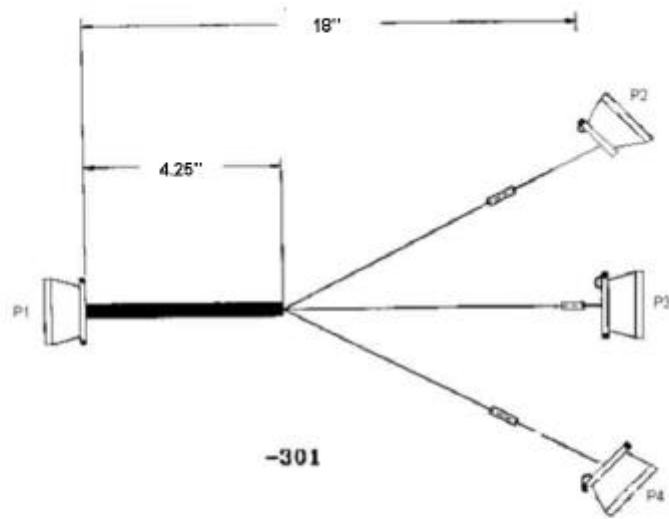
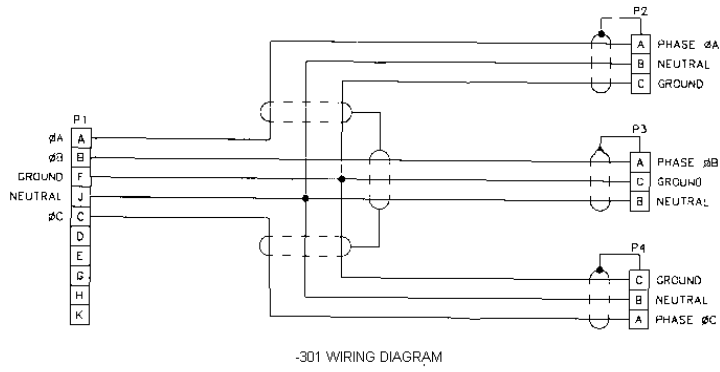
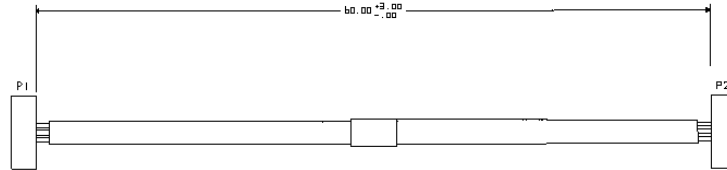

FIGURE 7-5 AC POWER W-CABLE - SED46117140-301



- 302 WIRING DIAGRAM
- 303 WIRING DIAGRAM
- 304 WIRING DIAGRAM
- 305 WIRING DIAGRAM



- 302
- 303 { 120.00 LG }
- 304 { 180.00 LG }
- 305 { 240.00 LG }

FIGURE 7-6 AC POWER W-CABLE EXTENSIONS- SED46117140-302 THROUGH -305

7.2 COMMUNICATION CABLES

Communication with payloads is accomplished via cables provided for the RS-232C port (for cabin payloads), and the two RS-422A ports (for payload bay payloads).

7.2.1 RS-232C Cables

Two 14-foot RS-232C cables are provided for experiments located in the orbiter cabin. The first cable, a DB9 (female) to DB25 (male) part number SED33103335, is fully compatible with an IBM AT serial cable. The second cable is a DB9 (female) to DB9 (male), part number SED33103348. Refer to Table 7-I for the proper connector mates. For details of each cable schematic, see Figures 7-7 and 7-8. RS-232 Y and Quad cables are also provided for PCMMU PGSC output to experiment PGSC connections.

Table 7-I. - RECOMMENDED CONNECTOR MATES FOR THE RS-232C CABLES

	Cable end	Experimenter/panel mate	Jack/Port
25-pin (Figure 7-4)	AMP206800-2	AMP206801-2 *	ITT D110551
9-pin (Figure 7-5)	AMP207252-2	AMP207253-2 *	ITT D110551

* or equivalent

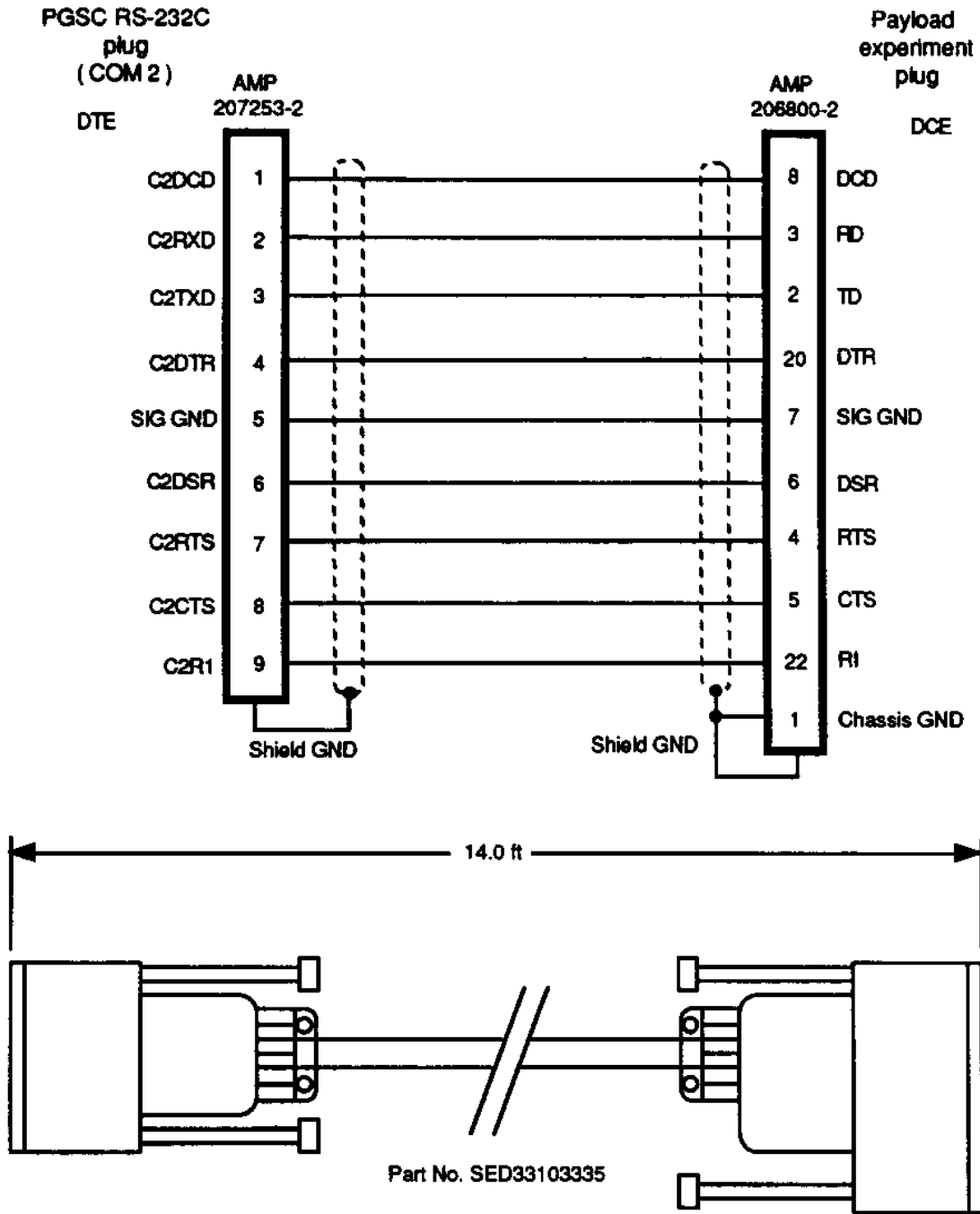

FIGURE 7-7 DB9F TO DB25M RS-232C CABLE SCHEMATIC.

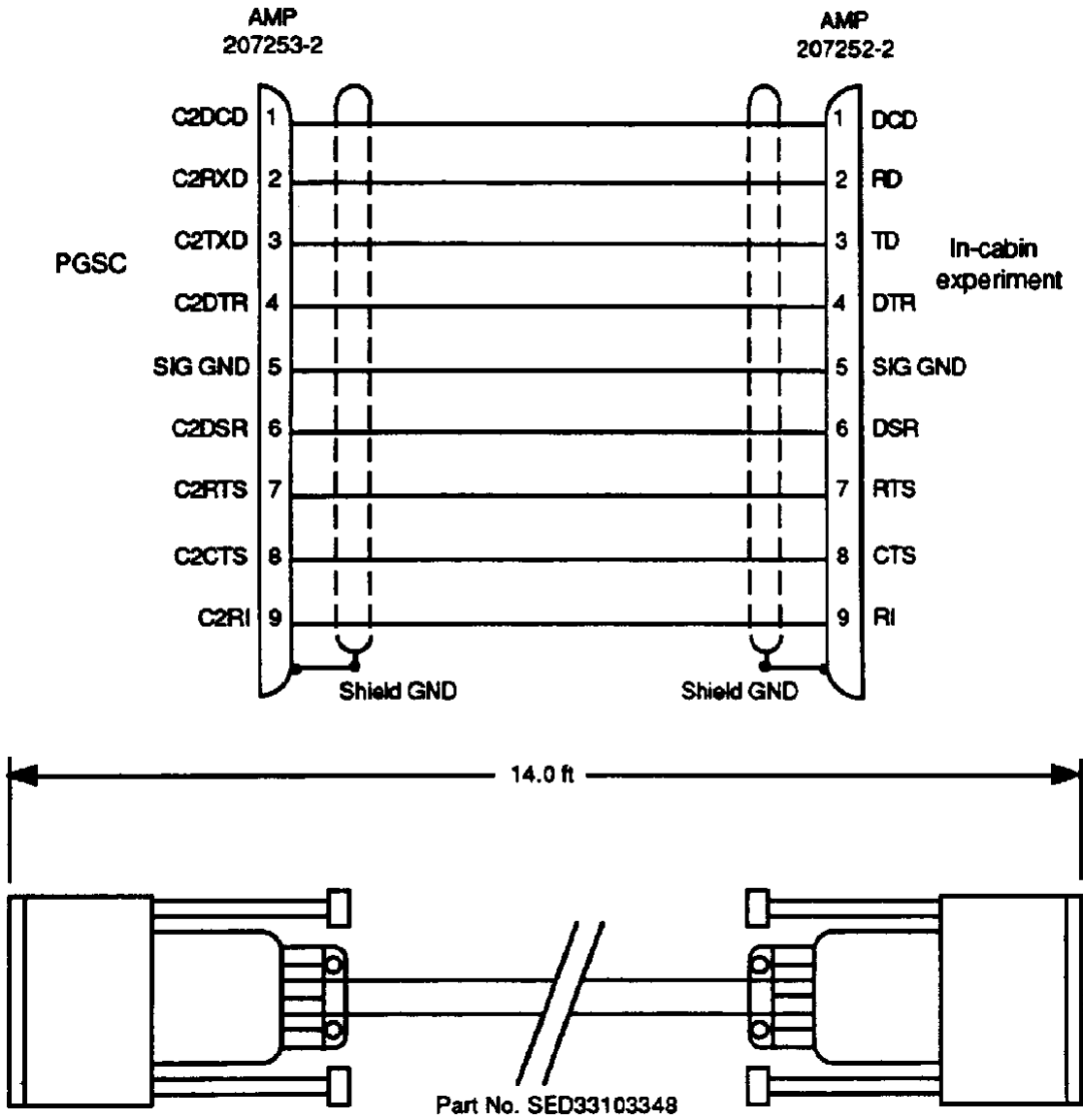

FIGURE 7-8 DB9F TO DB9M RS-232C CABLE SCHEMATIC.

7.2.2 RS-422A Cables

One RS-422A cable provides a communication link between the PGSC and payload in the payload bay. This cable connects the PDIP or CIP to the PGSC. The PDIP/CIP connector has a part number of NLS6GT12-35P and is a male connector. The CIP and PDIP are shown in Figures 7-9 and 7-10. A DB9-S female connector mates with an RS-422 adapter to the PCMCIA RS-422 card/cable assembly. In addition, a DB9-S female connector mates with RS-422A connector located on the Expansion Assembly of the PGSC (Configuration 5). A schematic of this cable is provided in Figure 7-11.

The RS-422A Y cable is used to transfer information between two or three PGSC's. A schematic is provided in Figure 7-12.

The PDIP RS-422A Y cable provides a communication link between the payload and two PGSC configurations. A schematic is provided in Figure 7-13.

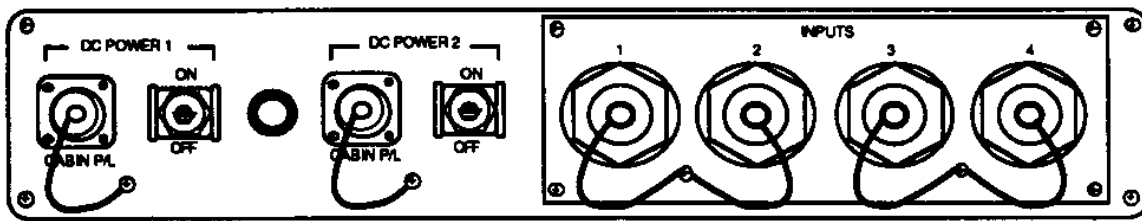

FIGURE 7-9 COMPUTER INTERFACE PANEL (CIP)

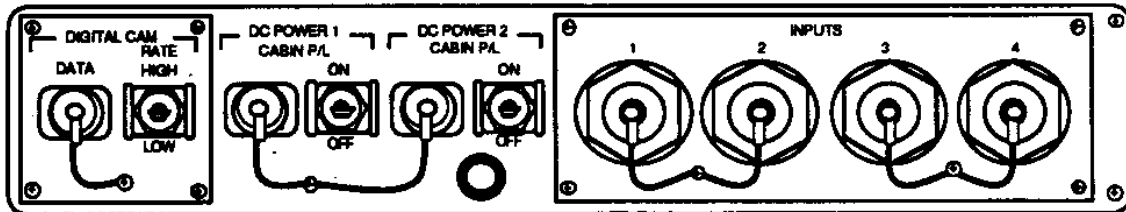

FIGURE 7-10 PAYLOAD DATA INTERFACE PANEL (PDIP)

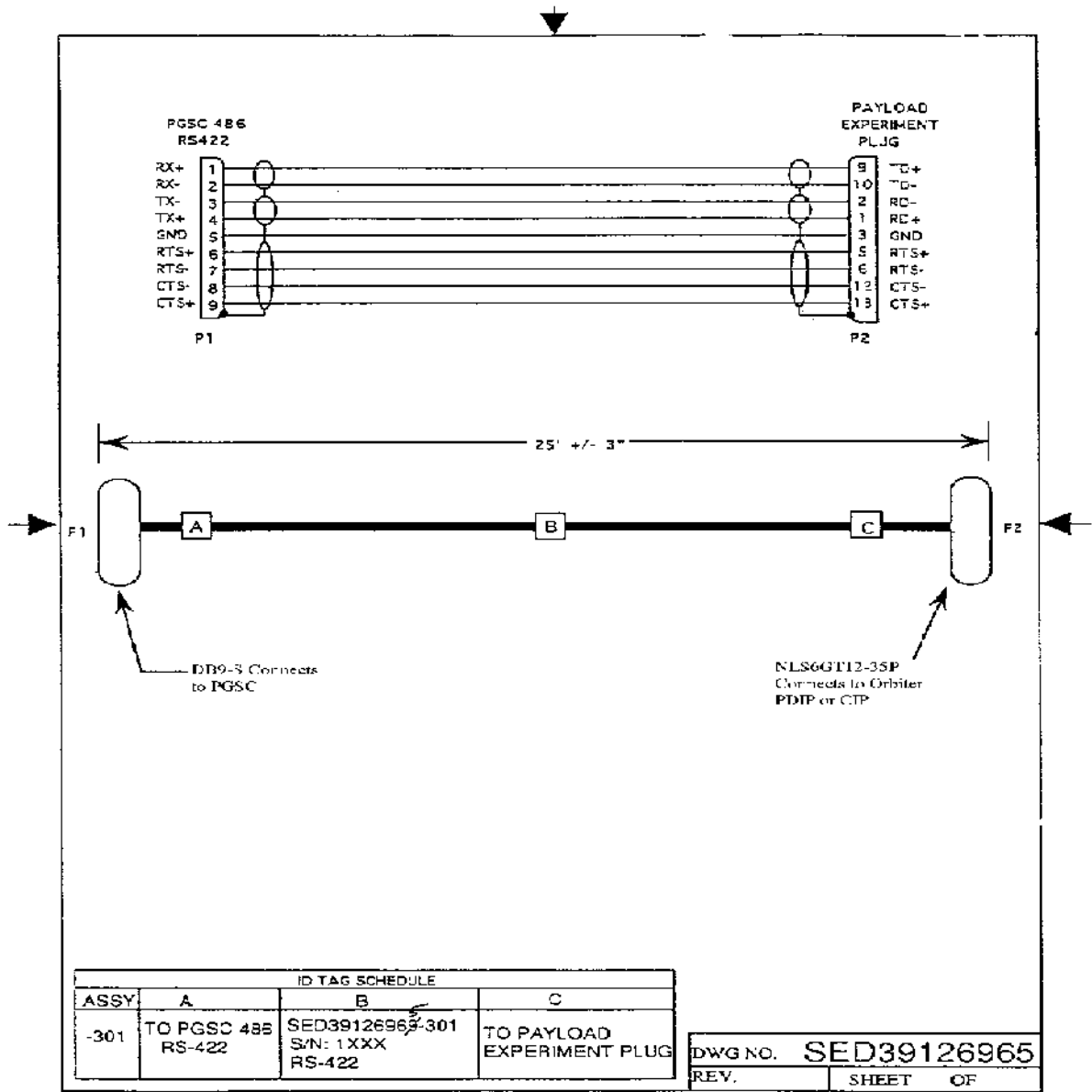

FIGURE 7-11 RS-422A/CHANNEL 1 CABLE SCHEMATIC

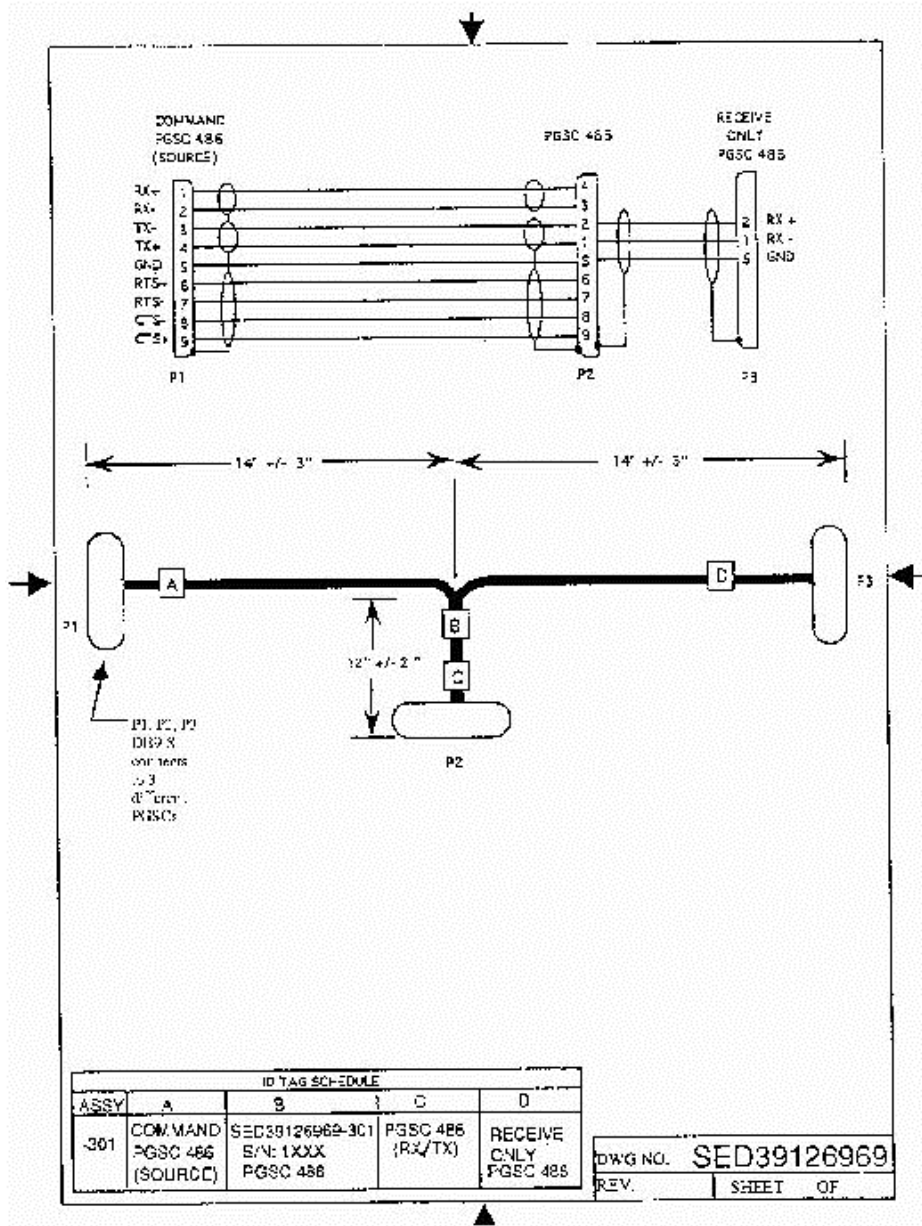

FIGURE 7-12 RS-422A Y/CABLE SCHEMATIC

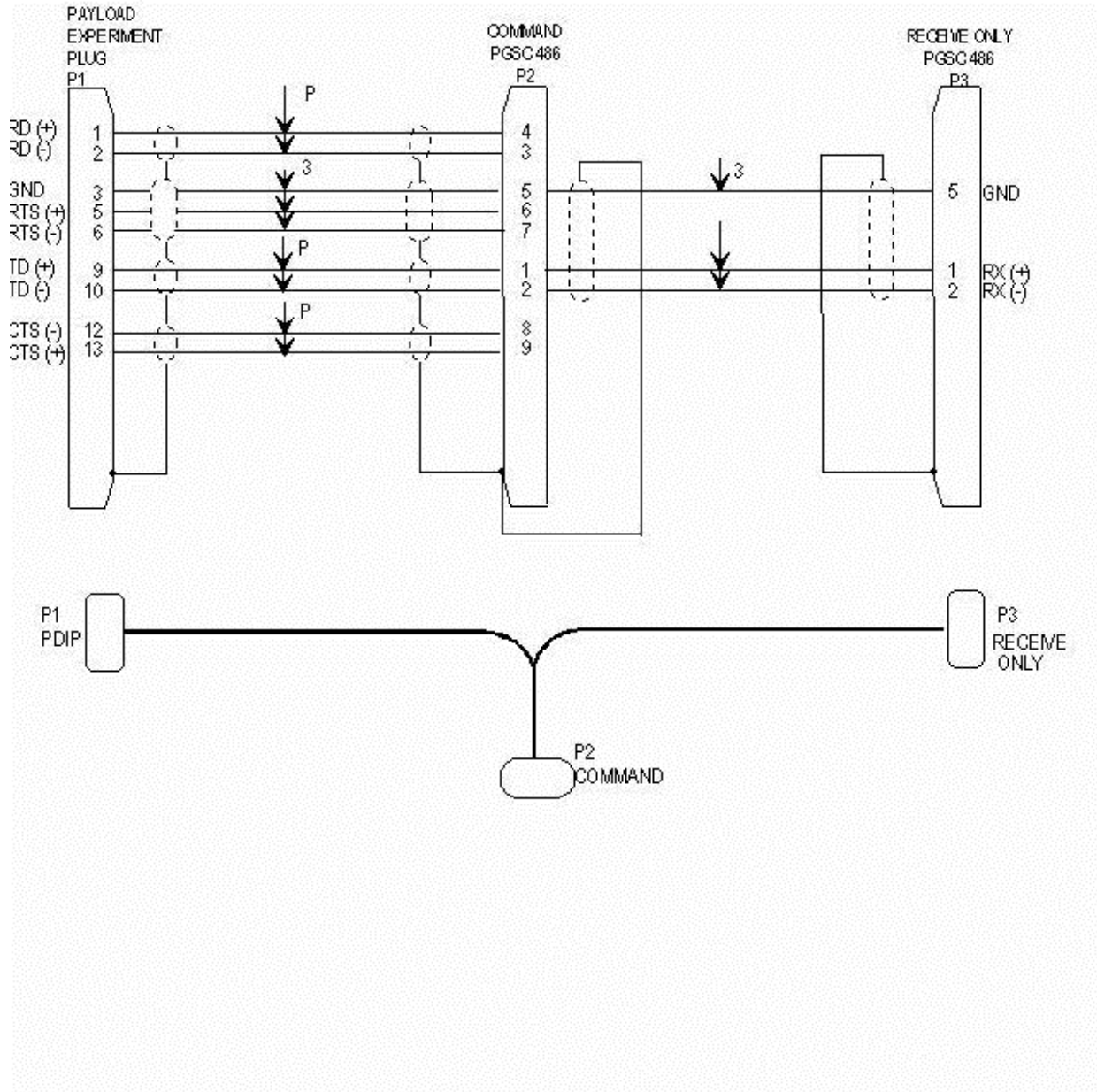

FIGURE 7-13 SED39126972 - PDIP RS-422 Y CABLE

8.0 MISCELLANEOUS

8.1 APPROVED FLOPPY DISKS

The Customer is responsible for providing floppy disks needed to support their payload. The following floppy disks have been tested and approved for flight:

- 3M Micro Diskettes, 3.5" double-sided, high density, 2.0 MB, manual part number 051111-12513
- Dysan Micro Floppy Disks, 3.5" double-sided, high density, 2.0 MB manual part number 814937-01

Approved labels are as follows:

- Avery Diskette Laser Labels, 3.5" diskette laser labels, blue, manual part number 5896
- Fasson double-sided adhesive film, manual part number 489
- Xerox paper, 8.5" x 11" and 8.5" x 14", white, type 4200, manual part number 3R721

8.2 APPROVED WRITABLE CDs

The Customer is responsible for providing CDs needed to support their payload. The following CD-ROMs have been tested and materially approved for flight:

- Verbatim P/N 91226
- Memorex P/N 3202-3404
- Sony P/N CDQ-74BN
- Eastman Kodak P/N 8670028

8.3 CD GENERATION PROCEDURES

Significant difficulty has been encountered using the ThinkPad 760XD with the 8X CD-ROM drive when reading CDs that had been burned in-house. Many CDs could not be read at all, while others would work on one machine, but not on another. To understand the cause, testing was performed with variation made to the blank CD-ROM brand, burning software, burning speed, and computer/burner platform.

The results indicate that the software used and the speed of the burning process are the most significant factors. The only CDs that were successfully read by all tested machines were written at single (1X) speed. Therefore, the POCCB strongly recommends that all CDs to be used on orbit be burned at single (1X) speed. Also, either HyCD version 1.2, or Adaptec Direct CD version 2.5a CD-ROM writing software should be used.

APPENDIX A - ACRONYMS AND ABBREVIATIONS

A/G	air-to-ground
ac	alternating current
ASCII	American Standard Code for Information Interchange
ATU	audio terminal unit
BIOS	basic input/output services
bps	bits per second
CGA	color graphics adapter
CIP	Computer Interface Panel
CMOS	Complementary Metal Oxide Silicon
COM	communication
COTS	commercial off the shelf
CPU	central processing unit
CTS	clear to send
dB	decibel(s)
dBm	decibel(s) referred to 1 milliwatt
dc	direct current
DPSK	differential phase shift keying
DRAM	Dynamic random access memory
EIA	Electronics Industries Association
EMC	Electromagnetic Compatibility
EMS	extended memory standard
FPU	Floating Point Unit
FRR	Flight Readiness Review
FSP	fault summary page
ft	foot, feet
GDU	ground development unit
GFE	Government furnished equipment
GMT	Greenwich mean time
GPC	General Purpose Computer
Hz	hertz

I/O	input/output
in.	inches
IRQ	interrupt request
ISO	International Organization for Standardization
JSC	Johnson Space Center
KB	kilobyte
lb	pound
LCD	liquid crystal display
LIM	Lotus-Intel-Microsoft
mA	milliampere
MB	megabyte
MCC	Mission Control Center
Meg	megabyte
MET	mission elapsed time
MΩ	megohm
MS-DOS	Microsoft-disk operating system
NASA	National Aeronautics and Space Administration
NTSC	National Television Standards Committee
OCA	Orbiter Communications Adapter
P/N	part number
PADM	portable audio data modem
PAL	phase-alternation-by-line
PC	personal computer
PCMCIA	Personal Computer Memory Card Internal Association
PCMMU	Pulse Code Modulation Master Unit
PDIP	payload data interface panel
PGSC	payload and general support computer
PIP	Payload Integration Plan
POC	Portable Onboard Computer
POCCB	Portable Onboard Computer Control Board
PS	power supply
psi	pounds per square inch
PTT	push to talk

PWR	power
RAM	random access memory
RGB	red/green/blue
ROM	read only memory
RS	recommended standard
RTS	request to send
SCSI	small computer system interface
SIP	System Integration Plan
SpOC	Space Operations Computing
SSP	Space Shuttle Program
SVGA	Super Video Graphics Array
TSR	Terminate/Stay Resident
Vac	volts, alternating current
Vdc	volts, direct current
VGA	Video Graphics Array
W	watt(s)
WIGSD	Windows Interface Guidelines for Software Design
XGA	extended graphics array
XMS	extended memory standard

ANNEX 1

Standard PGSC Flight Configurations

PGSC Flight Computer Configuration 1 - Standalone

In this configuration, the PGSC is an IBM ThinkPad 760XD laptop computer, modified for flight, with no Expansion Assembly. The external DC Power Supply is required with this configuration. The ThinkPad computer comes with a Pentium 166 MHz CPU.

Standard Installed Equipment:

Nomenclature	Part Number
760XD Computer	SDZ39129262-3XX
NiMH Battery Pack*	SEG39129286-301
Removable 8X CD-ROM Drive	SDZ39129265-301
Removable Hard Drive (3 GB)	SEZ39129266-301
*BATTERY PACK REMOVED	

Support Equipment:

Nomenclature	Part Number
DC Power Adapter Cable	SED39126013-301
DC Power Supply Assembly	SED39126010-305
DC Power Cable (6 ft.)	SED39122875-301
DC Power Cable (25ft.)	SED33103334-311
RS-232A Cable (9-9 pin)	SED33103348-307
RS-232C Cable (25-9 pin)	SED33103335-305
RS-232 Quad Cable	SED39126980-301
RS-232 Y Cable	SED39124826-301
Video In-Out Cable	SEZ39131213-301
Ethernet PC Card/Cable Assembly	SDZ39129269-301
Network Cable (3ft.)	SED39129316-301
Network Cable (25ft.)	SED39129317-301
Network "T" Connector	SED39129318-301
Network Terminator	SED39129319-301
PCMCIA SCSI Card with Cable	SED33107171-301
RS-422 Quatech Card/Cable Assembly	SDZ39129284-301
RS-422 Adapter	SEZ39121212-301
RS-422 Cable (25ft)	SED39126965-301
RS-422 PDIP Y-Cable	SED39126972-301
RS-422 Y Cable	SED39126969-301

PGSC Expansion Assembly Configuration 2 - PCMMU

In this configuration, the PGSC is an IBM ThinkPad 760XD laptop computer and an IBM SelectaDock Expansion Unit that contains a Sealevel ACB-530 advanced communication board for PCMMU. All units have been modified for flight.

Standard Installed Equipment:

Nomenclature	Part Number
760XD Computer	SDZ39129262-3XX
SelectaDock I Expansion Unit	SEZ39131224-301
Expansion Unit Base	SEZ39131223-301
PCMMU PC Board	SED39126967-301
Removable 8X CD-ROM	SDZ39129265-301
Removable Hard Drive (3 GB)	SEZ39129266-301
NiMH Battery Pack*	SEG39129286-301
* BATTERY PACK OPTIONAL	

Support Equipment:

AC "W" Power Cable	SED46117063-301
RS-232A Cable (9-9 PIN)	SED33103348-307
RS-232C Cable (25-9 PIN)	SED33103335-305
PCMMU (24 FT) Cable	SED39126005-301
PCMMU PORT Mode (1 ft) Cable	SED39126026-301
RS-232 Y Cable	SED39124826-301
RS-232 Quad Cable	SED39126980-301
Video In/Out Cable	SEZ39131213-301
Ethernet PC Card/Cable Assembly	SDZ39129269-301
Network Cable (3ft.)	SED39129316-301
Network Cable (25ft.)	SED39129317-301
Network "T" Connector	SED39129318-301
Network Terminator	SED39129319-301
PCMCIA SCSI Card with Cable	SED33107171-301
RS-422 Quatech Card/Cable Assembly	SDZ39129284-301
RS-422 Adapter	SEZ39121212-301
RS-422 Cable (25 ft)	SED39126965-301
RS-422 PDIP Y-Cable	SED39126972-301
RS-422 Y Cable	SED39126969-301

PGSC Expansion Assembly Configuration 3 - OCA

In this configuration, the PGSC is an IBM ThinkPad 760XD laptop computer and an IBM SelectaDock Expansion Unit that contains an OCA PC board for Ku-band and Modem interfaces. All units have been modified for flight.

Standard Installed Equipment:

Nomenclature	Part Number
760XD Computer	SDZ39129262-3XX
SelectaDock I Expansion Unit	SEZ39131224-301
Expansion Unit Base	SEZ39131223-301
OCA PC Board	SED16102686-301
Removable Hard Drive (3 GB)	SEZ39129266-301
Removable 8X CD-ROM	SDG39129265 -301
NiMH Battery Pack*	SEG39129286-301
* BATTERY PACK OPTIONAL	

Support Equipment:

Nomenclature	Part Number
AC "W" Power Cable	SED46117063-301
RS-232A Cable (9-9 PIN)	SED33103348-307
RS-232C Cable (25-9 PIN)	SED33103335-305
RS-232 Y Cable	SED39124826-301
RS-232 Quad Cable	SED39126980-301
Video In/Out Cable	SEZ39131213-301
OCA Ku-band/Audio Cable	SED16102693-301
Modem Cable (25 ft.)	SED33104173-301
Ethernet PC Card/Cable Assembly	SDZ39129269-301
Network Cable (3ft.)	SED39129316-301
Network Cable (25ft.)	SED39129317-301
Network "T" Connector	SED39129318-301
Network Terminator	SED39129319-301
PCMCIA SCSI Card with Cable	SED33107171-301

PGSC Expansion Assembly Configuration 4 - ProShare

In this configuration, the PGSC is an IBM ThinkPad 760XD laptop computer and an IBM SelectaDock Expansion Unit that contains a ProShare PC Board to allow for video communication on the network when OCA Router is running. All units have been modified for flight.

Standard Installed Equipment:

Nomenclature	Part Number
760XD Computer	SDZ39129262-3XX
SelectaDock I Expansion Unit	SEZ39131224-301
Expansion Unit Base	SEZ39131223-301
ProShare PC Board	SED16102920-303
Removable Hard Drive (3 GB)	SEZ39129266-301
Removable Floppy Drive	SEG39129288-301
NiMH Battery Pack*	SEG39129286-301
* BATTERY PACK OPTIONAL	

Support Equipment:

Nomenclature	Part Number
AC "W" Power Cable	SED46117063-301
RS-232A Cable (9-9 PIN)	SED33103348-307
RS-232C Cable (25-9 PIN)	SED33103335-305
RS-232 Y Cable	SED39124826-301
RS-232 Quad Cable	SED39126980-301
Video In/Out Cable	SEZ39131213-301
Ethernet PC Card/Cable Assembly	SDZ39129269-301
Network Cable (3ft.)	SED39129316-301
Network Cable (25ft.)	SED39129317-301
Network "T" Connector	SED39129318-301
Network Terminator	SED39129319-301
PCMCIA SCSI Card with Cable	SED33107171-301
RS-422 Quatech Card/Cable Assembly	SDZ39129269-301
RS-422 Adapter	SEZ39121212-301
RS-422 Cable (25 ft)	SED39126965-301
RS-422 PDIP Y-Cable	SED39126972-301
RS-422 Y Cable	SED39126969-301

PGSC Expansion Assembly Configuration 5 - RS-422

In this configuration, the PGSC is an IBM ThinkPad 760XD laptop computer and an IBM SelectaDock Expansion Unit that contains a Sealevel ISO-COM 3417 dual RS-422 PC Card. All units have been modified for flight.

Standard Installed Equipment:

Nomenclature	Part Number
760XD Computer	SDZ39129262-3XX
SelectaDock I Expansion Unit	SEZ39131224-301
Expansion Unit Base	SEZ39131223-301
RS-422 ISO COM PC Board	SED39126966-301
Removable Hard Drive (3 GB)	SEZ39129266-301
Removable 8X CD-ROM	SDZ39129265-301
NiMH Battery Pack*	SEG39129286-301
* BATTERY PACK OPTIONAL	

Support Equipment:

Nomenclature	Part Number
AC "W" Power Cable	SED46117063-301
RS-232A Cable (9-9 PIN)	SED33103348-307
RS-232C Cable (25-9 PIN)	SED33103335-305
RS-232 Y Cable	SED39124826-301
RS-232 Quad Cable	SED39126980-301
Video In/Out Cable	SEZ39131213-301
Ethernet PC Card/Cable Assembly	SDZ39129269-301
Network Cable (3ft.)	SED39129316-301
Network Cable (25ft.)	SED39129317-301
Network "T" Connector	SED39129318-301
Network Terminator	SED39129319-301
PCMCIA SCSI Card with Cable	SED33107171-301
RS-422 Cable (25 ft)	SED39126965-301
RS-422 PDIP Y-Cable	SED39126972-301
RS-422 Y Cable	SED39126969-301