

JSC 27891

Shuttle/Payload Configuration Management Plan  
for the **Payload and General Support Computer**  
**(PGSC)**

**Space Shuttle Vehicle Engineering Office**

October 1997

**NASA**

National Aeronautics and  
Space Administration

Lyndon B. Johnson Space Center  
Houston, Texas 77058

**REVISION HISTORY**

REVISION/ DATE	DESCRIPTION	POCCB APPROVAL	DATE

**Shuttle/Payload Configuration Management Plan  
for the  
Payload and General Support Computer  
September 1997**

Approved by

Originally Signed by:

Bobby Watkins  
Space Shuttle Program,  
Avionics and Software Office  
Group  
Co-Chairman,  
Portable Onboard Computer Control Board

Originally Signed by:

Neil Woodbury  
Mission Operation Directorate,  
Portable Onboard Computing and Tools  
Co-Chairman,  
Portable Onboard Computer Control Board

Originally Signed by:

Darrell Stamper  
Space Shuttle Program  
Manager,  
Avionics and Software Office  
Office

Originally Signed by:

Ronald Dittmore  
Space Shuttle Program  
Manager,  
Space Shuttle Vehicle Engineering

**NATIONAL AERONAUTICS AND SPACE ADMINISTRATION  
LYNDON B. JOHNSON SPACE CENTER  
HOUSTON, TEXAS 77058**

**Configuration Management Plan for the**

# **Payload and General Support Computer**

## **Sections**

### **1.0 Introduction**

- 1.1 Purpose**
- 1.2 Scope**
- 1.3 Authority**

### **2.0 References**

### **3.0 Organization**

- 3.1 PGSC Configuration Management**
  - 3.1.1 PGSC Interface Definition Document**
  - 3.1.2 PGSC Software Management Plan**

### **4.0 Board Meeting**

- 4.1 Membership**
- 4.2 POCCB Internet Information**

### **5.0 Change Management**

- 5.1 POCCB Change Request**
- 5.2 Flight Manifesting Change Request**
- 5.3 Discrepancy Report**

### **6.0 PGSC Loaner Hardware Process**

## **Figures**

**Attachment A – PGSC Hardware Manifesting Flow**

**Attachment B – POCCB Software Process**

## 1.0 INTRODUCTION

### 1.1 PURPOSE

The purpose of this document is to define the Payload and General Support Computer (PGSC) configuration management plan which will provide the governing control and implementation of laptop computer requirements for the Space Shuttle Program. This document establishes the responsibilities and activities needed to ensure proper integration, configuration, maintenance, and control of all proposed changes to the laptop products for the Shuttle Program.

### 1.2 SCOPE

All NASA and contractor organizations involved in PGSC activities necessary to achieve total program configuration objectives of the Space Shuttle Program (SSP) shall conform to the requirements set forward in this document.

### 1.3 Authority

The Portable Onboard Computing Control Board (POCCB) is the controlling authority for Payload and General Support Computers. The Office of Primary Responsibility (OPR) for the Shuttle/Payload Configuration Management Plan for the PGSC is the Space Shuttle Program, Avionics and Software Office. Changes or waivers will be handled via a POCCB CR, JSC-224. The POCCB will approve each change and will recommend a change/waiver disposition with final approval from the Space Shuttle Program, Avionics and Software Office, Manager.

## 2.0 References

NSTS 07700, Volume VI	Space Shuttle Program Configuration Management Requirements
NSTS 07700, Volume II	Space Shuttle Program Structure and Responsibilities
JSC 17038	Space Shuttle Program Flight Equipment Non-Critical Hardware Program Requirements Document
NSTS 21000	Shuttle/Payload Interface Definition Document for the Payload and General Support Computer
JSC 22448	Portable Onboard Computer Software Management Plan

### 3.0 Organization

The configuration management of the PGSC is the responsibility of the POCCB. The POCCB is a Co-Chaired Board by the Space Shuttle Program, Avionics and Software Office, and the Mission Operations Directorate, Portable Onboard Computing/Tools Office.

#### 3.1 PGSC Configuration Management

The POCCB is responsible for approving the hardware and software requirements needed to meet the flight specific PGSC system configurations for crew and payload support. The POCCB will disposition Portable Onboard Computer (POC) CRs to define the requirements for hardware, software and ancillary peripherals for each Shuttle Flight. The focal point for each flight will be the POC Coordinator. This individual is considered the PGSC expert for that flight. The POC Coordinator ensures proper integration of flight software onto the flight PGSC hardware. Once the flight PGSC system is configured, the hardware is provided to the GFE Bench Review for crew visual inspection. Two governing documents used to control the PGSC Configuration Management include the PGSC Interface Definition Document and the PGSC Software Management Plan.

##### 3.1.1 PGSC Interface Definition Document

The PGSC hardware interfaces are documented in the Shuttle/Payload Interface Definition for the Payload and General Support Computer, NSTS 21000-IDD-486, Rev A. The Office of Primary Responsibility for this document is the SSP, Avionics and Software Office. This document defines all interfaces available to the PGSC and identifies configurations for the government furnished equipment (GFE) communications and power cables supplied with the PGSC. All changes to the document will occur via the POCCB CR , JSC-224.

##### 3.1.2 PGSC Software Management Plan

The PGSC software validation process is documented in the PGSC Software Management Plan JSC 22448. The Office of Primary Responsibility for this document is the Mission Operation Directorate, Portable Onboard Computing and Tool Office. This document provides direction, software delivery milestones, validation procedures, software configuration management, and overall guidelines for the PGSC software. All changes to this document will occur via the POCCB CR , JSC-224.

## 4.0 Board Meeting

The PGSC hardware/software technical issues, flight configurations, and strategy discussions are conducted monthly at the Portable Onboard Computing Control Board. The board meets monthly. The POCCB chairmen are responsible for the generation and content of the agenda and minutes for each board meeting. Agendas are published a week before the meeting via standard email distribution or via Internet. Minutes are also published for each meeting. Teleconferences are also available if requested two week prior to boards meetings.

At the POCCB, the overall integration of the PGSC hardware and software requirements for each Shuttle flight is discussed. The Flight PGSC Usage Charts are reviewed and approved at the POCCB. In addition, new systems (PGSC hw/sw) for crews and/or payloads are reviewed and approved at the POCCB meetings.

### 4.1 Membership

Participation is open to NASA and contractor personnel. Official membership is listed in the SSP Configuration Management Requirements, NSTS 07700, Volume IV - Book 1 for the POCCB. For organizations listed in the NSTS 07700 supporting the POCCB membership, participation is mandatory each month.

### 4.2 POCCB Internet Information

The POCCB has made available, via the Internet, various information for the PGSC. This document as well as the PGSC Interface Definition Document, Software Management Plan, PGSC Flight Usage Charts, etc. are available via the Internet. The Internet address of the POCCB home page is <http://fltproc.jsc.nasa.gov/POCCB>.

## 5.0 Change Management

### 5.1 POCCB Change Request (CR)

The POCCB Change Request, JSC 224 shall be used to request changes (hardware/software) to the Payload and General Support Computers for disposition by the POCCB. This form shall be used to establish all baseline configurations for the PGSC

system. This form may be obtained via the POCCB home page. The POCCB uses this form to track changes, assess magnitude of the requested change (cost/schedule), and identify the support organization performing the work.

## 5.2 Flight Manifesting CR

In addition to JSC 224, the FCE CR JSC Form 954A and JSC Form 482 are used in the PGSC Configuration Control process. The Flight Crew Equipment (FCE) Configuration Control Board CR, JSC Form 954A is used to manifest the specific flight STS PGSC hardware configurations for each Shuttle mission. For Payload PGSC hardware, Payload Integration Plans and Annex document can manifest PGSC hardware. The POC Coordinator ensures that all specific flight PGSC hardware is documented via JSC Form 954A (including PIP & Annex approved PGSC hardware). Attachment A shows a typical PGSC manifesting flow.

The 482 form is used to establish the PGSC Flight Software load. Typically, the POC Coordinator generates the JSC 482 for the STS flight software load. If software is being provided by another support organization to be incorporated in the flight software load, the supporting organization shall submit the JSC 482 form for their software. Attachment B shows the Software flow. Additional information on the use of this form can be obtain via POCCB.

## 5.3 Discrepancy Reports

A Discrepancy Report (DR) will be written when a PGSC hardware or software problem is discovered. The POCCB is responsible for the disposition of PGSC DRs. If a waiver is requested in response to a DR, it must be submitted for open discussion at the POCCB. If an ops note accompanies a waiver, it too must be submitted to the POCCB for dispositioning. The POCCB is responsible for maintaining the PGSC DR process. The PGSC DR process is defined in JSC 28015.

## 6.0 PGSC Loaner Hardware

Loaner PGSC hardware with power supplies and communications cabling may be obtained on loan for two week periods. Only approved manifested customers and supporting organizations may request loaner PGSC hardware. Any damage or abuse caused to the hardware will be levied to the customer.

JSC 27891

The SSP controls the loaner pool of PGSC's. The PGSC Loaner Form is completed by the requesting organization and is submitted to the POCCB chairman for approval. The loaner form includes information such as experiment name, experiment testing activities, expected start and completion date, and list of hardware being requested. The requesting organization should list software requirements (STS Load, PL Unique, etc.) for loaner hardware. The PGSC Loaner Form can be obtained via the POCCB Home Page and routed via email to the SSP POCCB Chairman for approval.

Baseline STS/Shared Requirements

## PGSC HW Manifesting Flow (Assume maximum 5 PGSC)

All duration's are work days

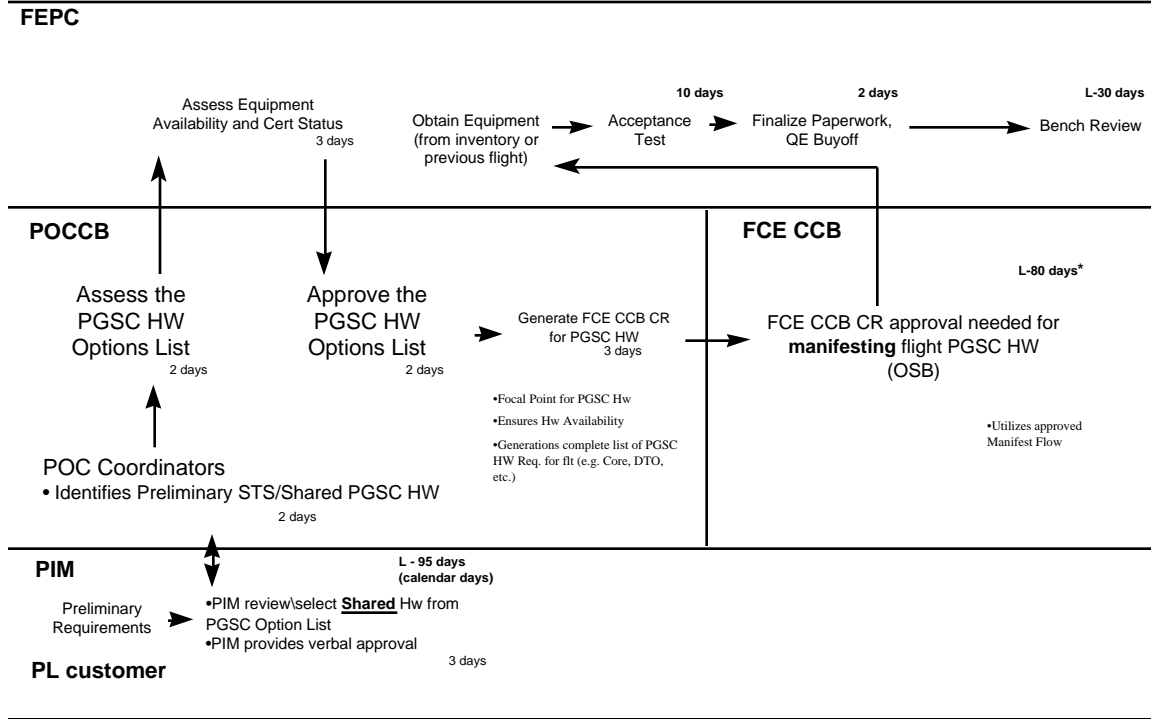

\* New requirement

## POCCB Software Process

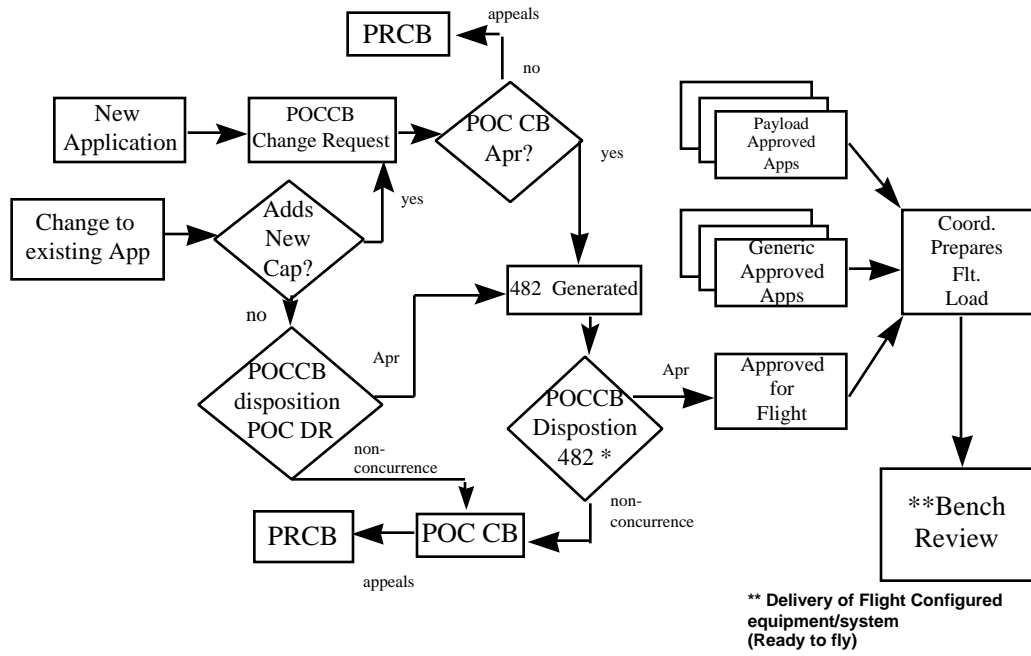

\* The POCCB disposition  
all PGSC related 482s